

KRACHT

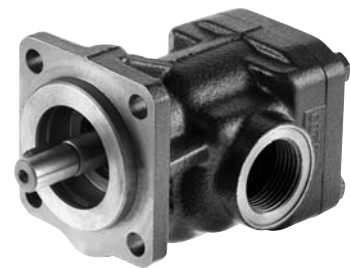

Transfer Gear Pumps

KF 4...112

Contents

Technical Data

	Page
Applications/Suitable fluids	4
Construction	5
Variants/Direction of rotation	6
ATEX version	7
Materials/Characteristics	8
Shaft end seals/Variants	9 – 10
Version noise optimized	11
Type key	12
Technical data	13
Discharge flow/Input power	14 – 15

Dimension Sheets

Flange-mounting version with pipe thread	Nominal size 4 – 25 . . .	16
Flange-mounting version with SAE 3/4 bzw. 1-connection (Special No. 158) . . .	Nominal size 4 – 25 . . .	17
Flange-mounting version with SAE 1 1/2-connection	Nominal size 32 – 80 . . .	18
Flange-mounting version with SAE 2-connection (Special No. 232)	Nominal size 50 – 80 . . .	19
Flange-mounting version with SAE 2-connection	Nominal size 100/112 . . .	20
Flange-mounting version with SAE 2 1/2-connection (Special No. 232)	Nominal size 100/112 . . .	21
Flange-mounting version with SAE 2-connection (Sealing 31)	Nominal size 100/112 . . .	22
Flange-mounting version with SAE 2 1/2-connection (Special No. 232, Sealing 31)	Nominal size 100/112 . . .	23
Pump with mounting angle, pipe thread	Nominal size 4 – 25 . . .	24
Pump with mounting angle, SAE 1 1/2-connection	Nominal size 32 – 80 . . .	25
Flange-mounting version with universal arrangement	Nominal size 4 – 25 . . .	26
Flange-mounting version with universal arrangement	Nominal size 32 – 80 . . .	27
Couplings		28
Bell housing	Nominal size 4 – 25 . . .	29
Bell housing	Nominal size 32 – 80 . . .	30
Bell housing	Nominal size 100/112 . . .	31
Motor-pump assemblies with pipe thread	Nominal size 4 – 25 . . .	32 – 33
Motor-pump assemblies with SAE 1 1/2-connection	Nominal size 32 – 80 . . .	34 – 35
Motor-pump assemblies with SAE 2-connection	Nominal size 100/112 . . .	36 – 37
Threaded flange G-SAE 3/4 / Welding flange S-SAE 3/4 / Threaded flange G-SAE 1 / Welding flange S-SAE 1 . .		38
Threaded flange G-SAE 1 1/2 / Welding flange S-SAE 1 1/2 / Threaded flange G-SAE 2 / Welding flange S-SAE 2		39
Threaded flange G-SAE 2 1/2 / Welding flange S-SAE 2 1/2 / Accessory liquid seal		40

Applications, Suitable Fluids

Applications

Centrifuge construction,
Coating machines, Compressors
Engine construction
Filling stations, Filter systems
Generator construction
Heat transfer systems, Heavy electrical machines
Lubricant manufacturers, Lubricating oil systems
Machine-building industry, Machine tools,
Manufacture of apparatus,
Marine engine construction,
Metal-forming machines, Metering systems
Paint industry, Plain metal bearing production,
Printing machines, PUR machinery
Refrigerators, Rubber and tire manufacturing
Tank plant construction,
Transmission building
Turbine construction
Vacuum machinery
Waste oil - disposal
 - transport
 - treatment

Suitable fluids

Adhesives, Antifreeze
Bore oils
Cutting oils
Diesel oils, Drawing compound
Emulsions
Fuel oils, L, EL, H
Gear oils, Grease
Hardening oils, Heat transfer media,
Heavy oils, Hydraulic fluids
Isocyanate
Lubricating oils, Lacquers
Motor oils
Paint, Paraffins, Plastics, Polyols
Printing inks, Processing oils
Resins, Rolling oils
Waste oils, Waxes

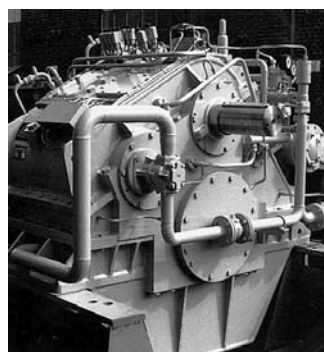
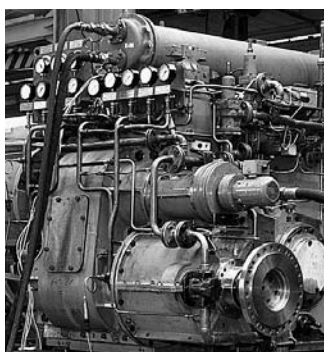
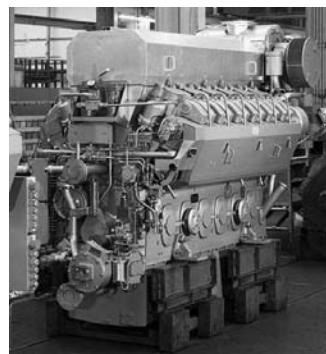

Construction

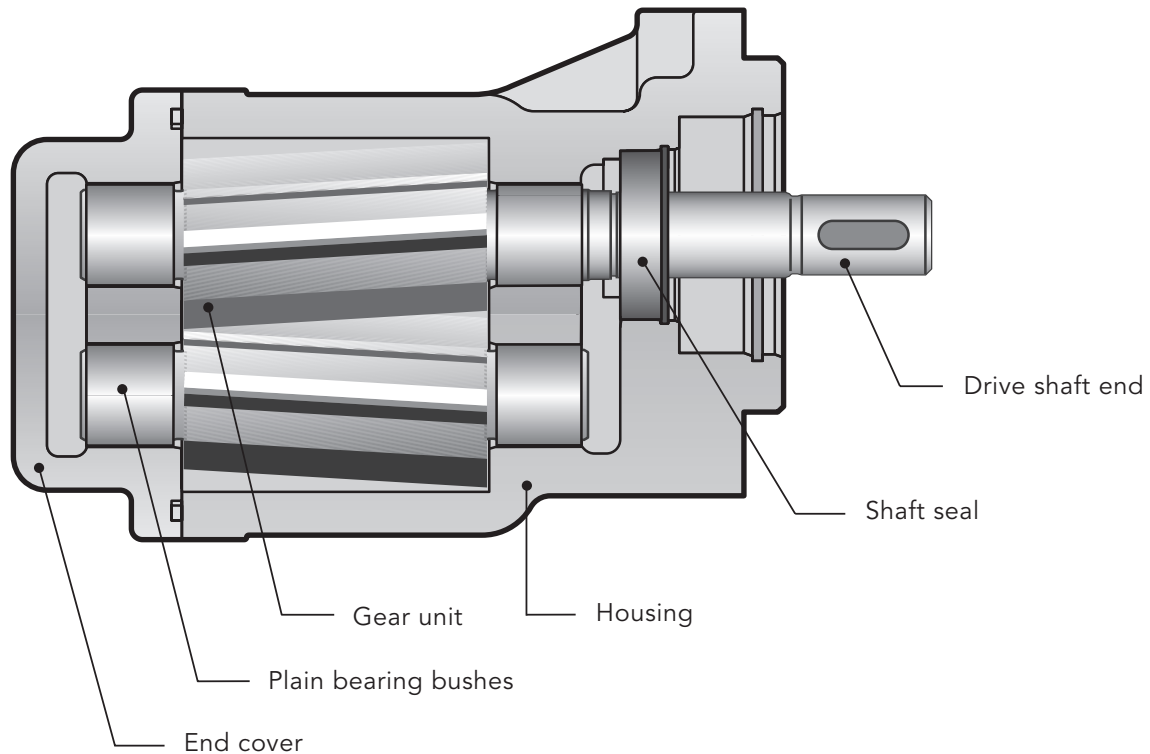

Product Features

Transfer gear pumps KF are used for pumping a wide variety of fluids.

Transfer gear pumps KF are distinguished especially by their wide range of variants which are assembled as required on the modular principle and also permit subsequent upgrade.

The pumps are also suitable for media with low lubricating properties.

The standard housing sections are of grey cast iron.

The gear units are manufactured from high-strength case-hardening steel, hardened and mounted in special multi-compound plain bearing bushes.

The standard drive shaft is sealed by rotary shaft lip-type seal.

All pump sizes incorporate helical tooth system. This feature, combined with special gear geometry, results in extremely low noise levels and reduced pressure pulsation.

Working Notes

- The fluids should ensure a certain minimum lubricating properties, should not contain solids and should be chemically compatible.
- Avoid dry operation.
- The pumps may only be operated in the specified direction of rotation, as otherwise the shaft seal will be destroyed.
- In order to prevent excessive overpressure, a safety valve should be provided in the system or on the pump.
- The pressure relief valve attached to the pump may only be used as safety valve for short-term operation.
- A separate pressure relief valve with return line to the reservoir must be foreseen, if a partial discharge flow has to be drained over a prolonged period.

Variants

- Sealing of the drive shaft:
 - Rotary shaft lip-type seal
 - Double rotary shaft lip-type seal (Quench)
 - Mechanical seal
- Outboard bearing to take up input drive-side radial load
- Pressure relief valve for pump and system
- Uniform discharge flow direction with changing direction of rotation by means of flange-mounting valve combination (universal device).

Special Design

Various shafts ends and gear units, as well as flange mounted versions, bearing alternatives, multi-stage pump combinations for your special application are available on request.

Our Sales engineers will be pleased to advise you.

Accessories

- Connecting flanges
- Couplings
- Bell housing
- Quench tank
- Attenuation elements

Direction of Rotation

The following should be note for direction of rotation:

- when looking at the pump shaft end, the direction of pumping is from left to right if the shaft rotates clockwise.
- when looking at the pump shaft end, the direction of pumping is from right to left if the shaft rotates counterclockwise.

Without pressure relief valve

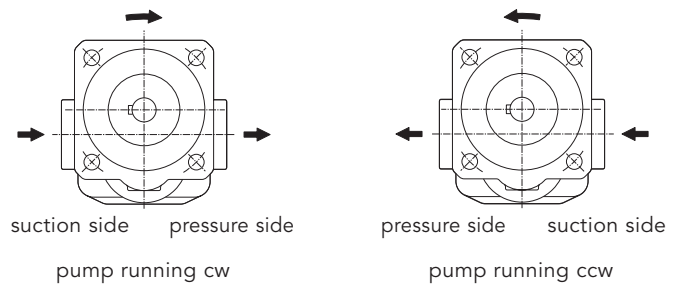

With pressure relief valve

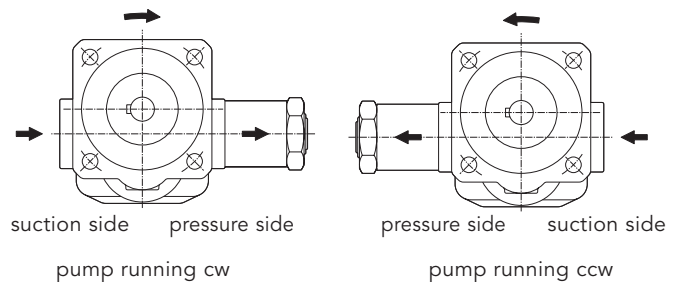

With universal device

Direction of rotation right and left

Direction of rotation consistent, see dimension sheets page 26 and 27.

ATEX Version

	KF 4...112 with lip-type seal	KF 4...112 with double lip-type seal
In Ex-area max. suitable for category	EX II 2G T4 EX II 2D T135 °C	EX II 2G T4
Perm. working pressure inlet port in bar	- 0.4 ... + 0.5	- 0.4 ... + 0.5
Perm. working pressure outlet port in bar	25	25
Perm. viscosity in mm²/s	12 ... 20 000	12 ... 20 000
Max. speed in 1/min (viscosity dependent)	3 000	3 000
Perm. mounting position	Horizontal or shaft end toward bottom	Horizontal quencher up
Perm. media temperatures in °C	- 10 ... + 80	- 10 ... + 80
Perm. ambient temperatures in °C	- 20 ... + 60	- 20 ... + 60
Comments	Vertical mounting with shaft end up on request. In executing with outboard bearing max. speed 1500 1/min. In dust Ex-area, permissible only with non-conductive dusts. Dust-proof capsuling of pump shaft and coupling required.	Not suitable for dust-Ex. Execution with quench feed and quencher.

Additional products available on request.

Materials

Housing and cover	EN-GJL-250 (GG 25) EN-GJS-400-15 (GGG 40) on request
Gear	Steel 1.7139
Plain bearing bushes	DU (multi-layer friction-type bearings P 10, DP 4) Bearings free of nonferrous metal on request
Shaft end seals	NBR, FKM, PTFE, EPDM (other sealing materials on request. E.g. HNBR/CR)
O-ring	NBR, FKM, PTFE, EPDM (other sealing materials on request. E.g. HNBR/CR)

Characteristics

Nominal sizes 4...112 cm ³	$V_g =$	4 / 5 / 6 / 8 / 10 / 12 / 16 / 20 / 25 / 32 / 40 / 50 / 63 / 80 100 / 112
Fitting position		KF... R/L/B ... without Quench optional KF... R/L/B ... with Quench horizontal, Quench connection above KF... U ... horizontal, Pressure connection above
Direction of rotation		right or left right and left
Fixing type		flange (DIN ISO 3019)
Pipe connection	KF 4...25 KF 32...112	Whitworth pipe thread, SAE flange SAE flange
Drive shaft end		ISO R 775 short-cylindrical
Working pressure suction side		see chart page 9
Working pressure pressure side	P_n	25 bar (higher pressures on request)
Speed	KF 4...112	200 ... 3 000 1/min
Viscosity (dependent on pressure and rotational speed)	mm ² /s	12 ... 20 000
Fluid temperature		see chart page 9
Ambient temperature	$V_u =$	-20 °C ... 60 °C (-4 °F ... 140 °F)

Shaft End Seals

	Sealing material	Pressure suction side* bar	Fluid temperature	
			°C	°F
Pump with single rotary shaft lip	NBR	-0.4...1.0	-10...90	14...194
	FKM max. 750 1/min max. 1000 1/min max. 1500 1/min max. 2000 1/min max. 3000 1/min	-0.4...6.0	-10...150	14...302
		-0.4...5.0		
		-0.4...4.0		
		-0.4...3.0		
		-0.4...2.0		
FKM (low temperature)	-0.4...0.5	-30**...150	-22**...302	
EPDM	-0.4...0.5	-10...120	14...248	
PTFE	-0.4...2.0	-10...200	14...392	
Pump with outboard bearing and single rotary shaft lip	NBR	-0.4...1.0	-10...90	14...194
	FKM max. 750 1/min max. 1000 1/min max. 1500 1/min max. 2000 1/min max. 3000 1/min	-0.4...6.0	-10...150	14...302
		-0.4...5.0		
		-0.4...4.0		
		-0.4...3.0		
		-0.4...2.0		
PTFE	-0.4...2.0	-10...200	14...392	
Pump with double rotary shaft seal with connection borehole for liquid seal (quench)	NBR	-0.4...1.0	-10...90	14...194
	FKM max. 750 1/min max. 1000 1/min max. 1500 1/min max. 2000 1/min max. 3000 1/min	-0.4...6.0	-10...150	14...302
		-0.4...5.0		
		-0.4...4.0		
		-0.4...3.0		
		-0.4...2.0		
PTFE	-0.4...2.0	-10...200	14...392	
Pump with double rotary shaft seal for vacuum operation with connection borehole for liquid seal (quench)	NBR	-0.9...0.2	-10...90	14...194
	FKM	-0.9...0.2	-10...150	14...302
	PTFE	-0.9...0.2	-10...200	14...392
Pump with triple rotary shaft seal for vacuum and normal operation with connection borehole for liquid seal (quench)	NBR	-0.9...1.0	-10...90	14...194
	FKM max. 750 1/min max. 1000 1/min max. 1500 1/min max. 2000 1/min max. 3000 1/min	-0.9...6.0	-10...150	14...302
		-0.9...5.0		
		-0.9...4.0		
		-0.9...3.0		
		-0.9...2.0		
Pump with mechanical seal	FKM	-0.4...10.0	-10...150	14...302
	PTFE	-0.4...10.0	-10...200	14...392
	EPDM	-0.4...10.0	-10...120	14...248
Pump with mechanical seal and connection borehole for liquid seal (quench)	FKM	-0.4...10.0	-10...150	14...302

Speed: 200–3000 1/min

The indicated maximum values are dependent upon the remaining working conditions.

In case of universal devices, pay attention to limitation of $P_{e \text{ min}}$.

Other sealing materials on request.

* short term during start-up status: -0.6 bar

** only in connection with housing and cover material EN-GJS-400 (GGG 40)

Variants

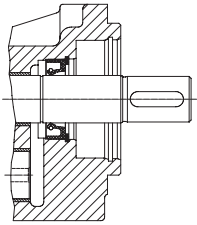

Pump with single rotary shaft lip

Fixing type: F/W

Sealing materials:

NBR = sealing type 1
 FKM = sealing type 2
 PTFE = sealing type 3
 EPDM = sealing type 9
 FKM low temperature = sealing type 23/31

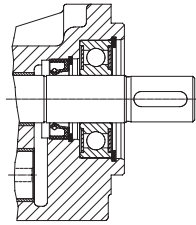

Pump with outboard bearing and single rotary shaft lip

Fixing type: G/X

Sealing materials:

NBR = sealing type 1
 FKM = sealing type 2
 PTFE = sealing type 3

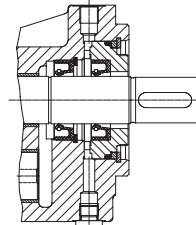

Pump with double rotary shaft seal with connection borehole for liquid seal (quench)

Fixing type: F/W

Sealing materials:

NBR = sealing type 19
 FKM = sealing type 7
 PTFE = sealing type 4
 EPDM = sealing type 32

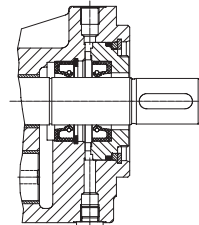

Pump with double rotary shaft seal for vacuum operation with connection borehole for liquid seal (quench)

Fixing type: F/W

Sealing materials:

NBR = sealing type 19
 FKM = sealing type 7
 PTFE = sealing type 4
 EPDM = sealing type 32
 Special number: 74

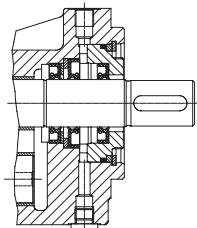

Pump with triple rotary shaft seal for vacuum and normal operation with connection borehole for liquid seal (quench)

Fixing type: F/W

Sealing materials:

NBR = on request
 FKM = on request

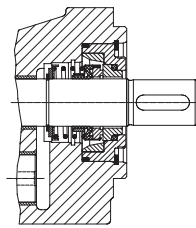

Pump with mechanical seal

Fixing type: F/W

Sealing materials:

FKM = sealing type 5
 PTFE = sealing type 6
 EPDM = sealing type 20

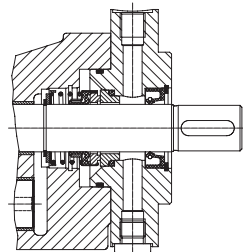

Pump with mechanical seal and connection borehole for liquid seal (quench)

Fixing type: F/W

Sealing materials:

FKM = sealing type 5
 Special number: 198

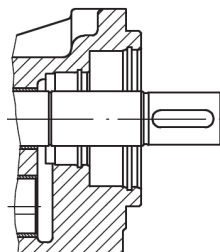

Pump without shaft sealing

Fixing type: F/W

Sealing material:

FKM o-ring = sealing type 30

KF 4...112 noise optimized

The noise optimized pumps in the KF series are designed for conveying media with higher proportions of air, predominantly for use as lubricating oil pumps in transmissions. Special measures prevent the otherwise normally increased noise present in auriferous transmission oil. The noise levels do not exceed or only barely exceed the measurements with non-auriferous oils. Also, there is no noise spectrum shift to higher, unpleasant frequencies. In applications without auriferous portions in the media, it is not recommended to use this version as it will not bring about noise reduction effects there.

The noise optimized version of the KF pump is marked with the special number **197** at the end of the type key. Pumps with the special number **197** are built as pumps in combination with an electric motor or as mounted pumps. The pump in combination with an electric motor (Fig. 1) does not have an outboard bearing, so it has to be driven via an elastic coupling. The mounted pump (Fig. 2) comes equipped with an outboard bearing to absorb the centrifugal forces such as those which arise when using a flying pinion. Pumps for electric motor drives and mounted pumps are sealed at the shaft end using a lip-type shaft seal.

Fig. 1

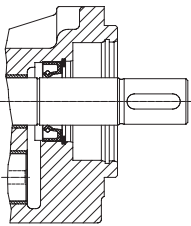

Pump with single rotary shaft lip
 Fixing type: F/W
 Sealing materials:
 NBR = sealing type 1
 FKM = sealing type 2
 Special number: 197

Fig. 2

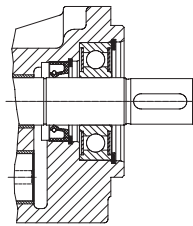

Pump with outboard bearing and single rotary shaft lip
 Fixing type: G/X
 Sealing materials:
 NBR = sealing type 1
 FKM = sealing type 2
 Special number: 197

The noise optimized version is also available in a ductile cast iron version. We can supply these pumps in the ATEX version also.

Note

Dimensions conformable standard pumps

Type Key (Ordering example)

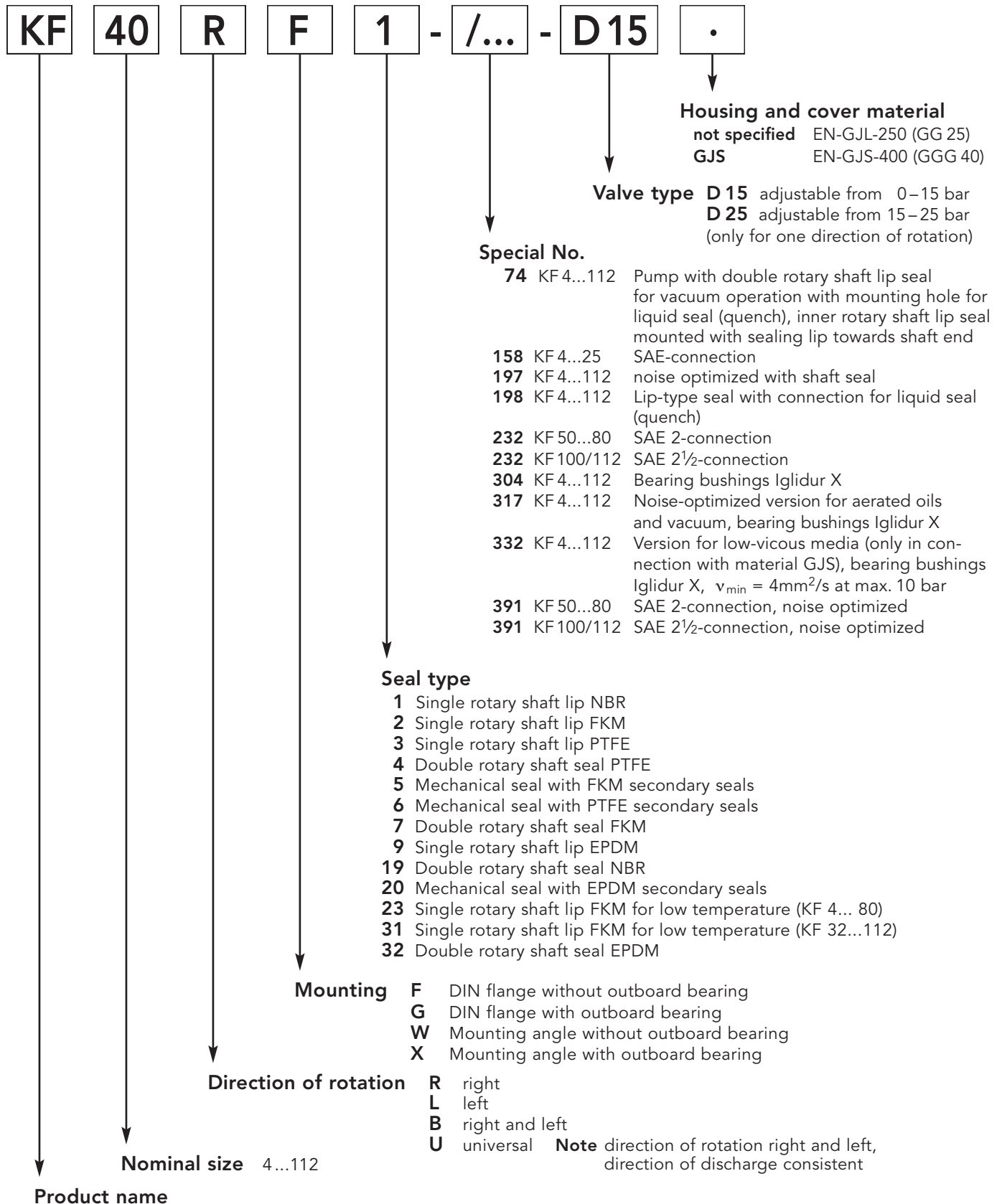

Technical Data

Nominal size	geom. displacement V_g cm ³ /r	Working pressure* p_b bar	Maximum pressure (pressure peaks) p_{max} bar	Speed range		Permissible load** (n = 1500 1/min) F_{radial} N	Sound level dB (A)		
				n_{min} 1/min	n_{max} 1/min		p = 5 bar	p = 15 bar	p = 25 bar
4	4.03	25	40	200	3000	700	≤ 65	≤ 66	≤ 67
5	5.05								
6	6.38								
8	8.05								
10	10.11								
12	12.58								
16	16.09								
20	20.1								
25	25.1								
32	32.12								
40	40.21								
50	50.2								
63	63.18								
80	80.5								
100	101.5	1500	≤ 67	≤ 68	≤ 68				
112	113.5					≤ 67	≤ 68	≤ 69	

Remark

* Working pressure p_b = perm. sustained pressure (higher pressures on request)

** Permissible load only for version with outboard bearing. F_{radial} at centre of shaft end.

For certain working conditions, the minimum or maximum characteristics should not be used.

For example, the max. working pressure is not permissible in combination with low speed and low viscosity.

In such limit ranges, please consult us.

Sound level measured in dB(A) at 1 m distance

Sound level measured with drive motor, installation site:

Works hall, quiet sound level = 40 dB(A)

Pump assembly on rigid fastening angle,

Suction and pressure conduits: Hose

Measured with transmission oil,

Oil viscosity $\nu = 34 \text{ mm}^2/\text{s}$,

Speed $n = 1500 \text{ 1/min}$.

Power Consumption

Speed n = 950 1/min

Discharge Q in l/min	Pressure p _b in bar								Nominal size	Pressure p _b in bar								Power consumption P in KW
	2	4	6	8	10	15	20	25		2	4	6	8	10	15	20	25	
	3.7	3.6	3.6	3.5	3.4	3.3	3.1	2.9		4	0.04	0.05	0.07	0.08	0.09	0.13	0.16	
4.6	4.5	4.5	4.4	4.3	4.1	3.8	3.6	5	0.04	0.06	0.08	0.10	0.11	0.16	0.20	0.25		
5.8	5.7	5.6	5.5	5.4	5.1	4.9	4.6	6	0.05	0.07	0.09	0.12	0.14	0.19	0.25	0.30		
7.3	7.2	7.1	7.0	6.8	6.5	6.2	5.8	8	0.06	0.09	0.11	0.14	0.17	0.24	0.31	0.38		
9.2	9.0	8.9	8.7	8.6	8.2	7.7	7.3	10	0.07	0.10	0.14	0.17	0.21	0.29	0.38	0.47		
11.4	11.3	11.1	10.9	10.7	10.2	9.6	9.1	12	0.08	0.12	0.16	0.21	0.25	0.36	0.47	0.58		
14.6	14.4	14.2	13.9	13.7	13.1	12.4	11.7	16	0.09	0.15	0.20	0.26	0.31	0.45	0.60	0.74		
18.2	18.0	17.7	17.4	17.1	16.3	15.5	14.7	20	0.10	0.18	0.25	0.32	0.39	0.56	0.74	0.92		
22.8	22.4	22.1	21.7	21.3	20.4	19.4	18.3	25	0.12	0.21	0.30	0.39	0.48	0.70	0.92	1.14		
29	29	28	28	27	26	25	23	32	0.2	0.3	0.4	0.5	0.6	0.9	1.2	1.5		
37	36	36	35	34	33	31	29	40	0.2	0.4	0.5	0.6	0.8	1.1	1.5	1.8		
46	45	44	43	43	41	38	36	50	0.3	0.5	0.6	0.8	1.0	1.4	1.9	2.3		
58	57	56	55	54	51	48	45	63	0.4	0.6	0.8	1.0	1.2	1.8	2.4	2.9		
73	72	71	69	68	65	61	58	80	0.4	0.7	1.0	1.3	1.6	2.3	3.0	3.7		
94	93	90	89	88	84	81	78	100	0.6	0.9	1.3	1.8	2.3	3.2	3.9	4.4		
100	99	97	96	94	93	88	83	112	0.8	1.0	1.6	2.2	2.8	3.5	4.5	5.0		

Speed n = 1450 1/min

Discharge Q in l/min	Pressure p _b in bar								Nominal size	Pressure p _b in bar								Power consumption P in KW
	2	4	6	8	10	15	20	25		2	4	6	8	10	15	20	25	
	5.7	5.6	5.6	5.5	5.4	5.3	5.1	4.9		4	0.06	0.08	0.10	0.12	0.15	0.20	0.25	
7.1	7.1	7.0	6.9	6.8	6.6	6.4	6.1	5	0.07	0.10	0.12	0.15	0.18	0.24	0.31	0.38		
9.0	8.9	8.8	8.7	8.6	8.3	8.0	7.8	6	0.08	0.11	0.15	0.18	0.21	0.30	0.38	0.47		
11.3	11.2	11.1	11.0	10.9	10.5	10.2	9.8	8	0.09	0.14	0.18	0.22	0.26	0.37	0.47	0.58		
14.2	14.1	14.0	13.8	13.6	13.2	12.8	12.4	10	0.11	0.16	0.21	0.27	0.32	0.45	0.58	0.72		
17.7	17.6	17.4	17.2	17.0	16.5	15.9	15.4	12	0.12	0.19	0.26	0.32	0.39	0.55	0.72	0.89		
22.6	22.4	22.2	22.0	21.7	21.1	20.5	19.8	16	0.16	0.26	0.37	0.47	0.57	0.82	1.08	1.33		
28.3	28.0	27.7	27.4	27.1	26.4	25.6	24.7	20	0.17	0.28	0.39	0.49	0.60	0.87	1.14	1.41		
35.3	35.0	34.6	34.3	33.9	32.9	31.9	30.9	25	0.20	0.34	0.47	0.61	0.74	1.08	1.41	1.75		
45	45	44	44	43	42	40	39	32	0.3	0.5	0.7	0.8	1.0	1.4	1.9	2.3		
56	56	55	55	54	52	50	49	40	0.4	0.6	0.9	1.1	1.3	1.8	2.3	2.9		
70	70	69	68	67	65	63	61	50	0.5	0.8	1.1	1.3	1.6	2.3	2.9	3.6		
89	88	87	86	85	82	79	77	63	0.7	1.0	1.3	1.7	2.0	2.9	3.7	4.5		
113	112	111	109	108	105	101	98	80	0.8	1.2	1.7	2.1	2.5	3.6	4.7	5.8		
145	144	141	140	139	135	132	129	100	1.2	1.7	2.2	2.7	3.2	4.4	5.7	6.9		
157	156	154	153	151	150	145	140	112	1.4	2.0	2.6	3.1	3.7	5.1	6.5	7.8		

The ratings refer to a mineral oil with a viscosity of 34 mm²/s.

Margin of error for the flow Q + 2.5 % ... - 5 % of the tabular value. For viscosity < 30 mm²/s, take a reduction of the rated flow Q into account.

The output of the drive motor should be selected 20 % higher than tabular value P.

For viscosity > 100 mm²/s, an increase in the required power is necessary, in this case proceed as per description on page 15.

Discharge Flow / Input Power

Calculation

$$P_{1Pu} = P_{tab} \cdot \frac{n}{1450} + f_v \cdot Q$$

P_{1Pu} = pump power consumption (kW)

P_{tab} = power consumption per table (kW) at 1450 1/min

n = speed (1/min)
dependent on viscosity!
(see speed recommendation)

f_v = viscosity factor $\left[\frac{\text{kW}}{\text{l/min}} \right]$
(see diagram)

Q = discharge flow (l/min) with $Q = \frac{V_g \cdot n}{1000}$

V_g = geometrical displacement (cm³/r)

Example: Pump type KF 80

Viscosity $\nu = 3000 \text{ mm}^2/\text{s}$

Working pressure $p = 15 \text{ bar}$

at $P_{tab} = 3.6 \text{ kW}$

$n = 500 \text{ 1/min}$

$f_v = 0.017 \frac{\text{kW}}{\text{l/min}}$

$$Q = \frac{80.5 \cdot 500}{1000} = 40 \text{ l/min}$$

becomes

$$P_{1Pu} = \left(3.6 \cdot \frac{500}{1450} + 0.017 \cdot 40 \right) \text{ kW}$$

$P_{1Pu} = 1.92 \text{ kW}$

Motorpower output: $P_{2Mot} = 1.2 \cdot P_{1Pu} = 2.3 \text{ kW}$

Select helical geared motor with

$P = 3.0 \text{ kW}$

$n = 500 \text{ 1/min}$

Conversion factors

$$1 \text{ bar} \triangleq 14.5 \frac{\text{lb}}{\text{in}^2} = 14.5 \text{ psi}$$

$$1 \frac{\text{l}}{\text{min}} \triangleq 0.220 \frac{\text{gal}}{\text{min}} = [\text{U.K.}]$$

$$1 \frac{\text{l}}{\text{min}} \triangleq 0.264 \frac{\text{gal}}{\text{min}} = [\text{US}]$$

Speed recommendation

Kinematic viscosity $\nu \text{ mm}^2/\text{s}$

< 300	300	500	1000	2000	3000	6000	10000	20000	30000
≥ 1500	1250	1000	750	600	500	400	300	200	100

Speed $n_{max} \text{ 1/min}$

Input Power



Diagramm: $n, f_v = f(\nu)$

Note:

To determine the power consumption, always take the max. working viscosity at starting state into consideration. The power of the drive motor should be selected 20% higher than the value determined.

Flange-Mounting Version with Pipe Thread

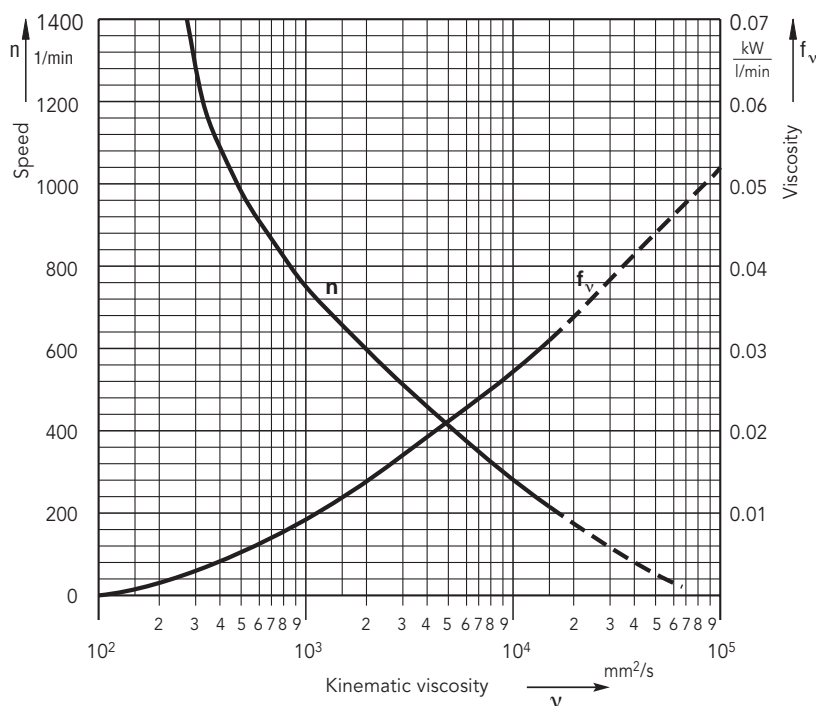
KF 4... 25

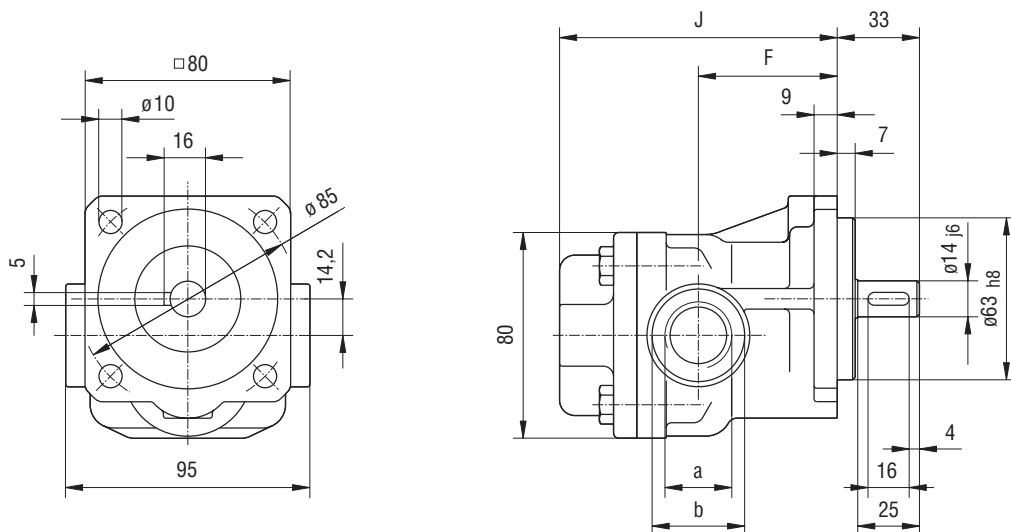

KF 4... 25 with pressure relief valve

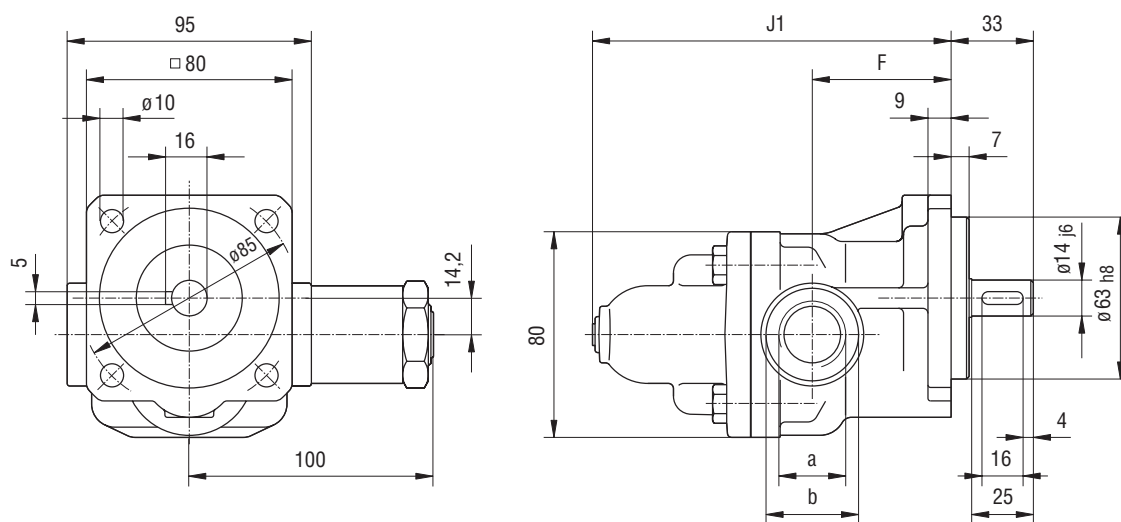

Nominal size	Suction and pressure connection		F	J	J ₁	Weight in kg	
	a	b				without valve	with valve
4...12	G 3/4 17 deep	Ø 36	54	109	140	2.9	3.7
16...25	G 1 19 deep	Ø 42	63	131	161	3.5	4.3

(Dimensions in mm)

Flange-Mounting Version with SAE 3/4 and 1-Connection (Special No. 158)

KF 4... 25

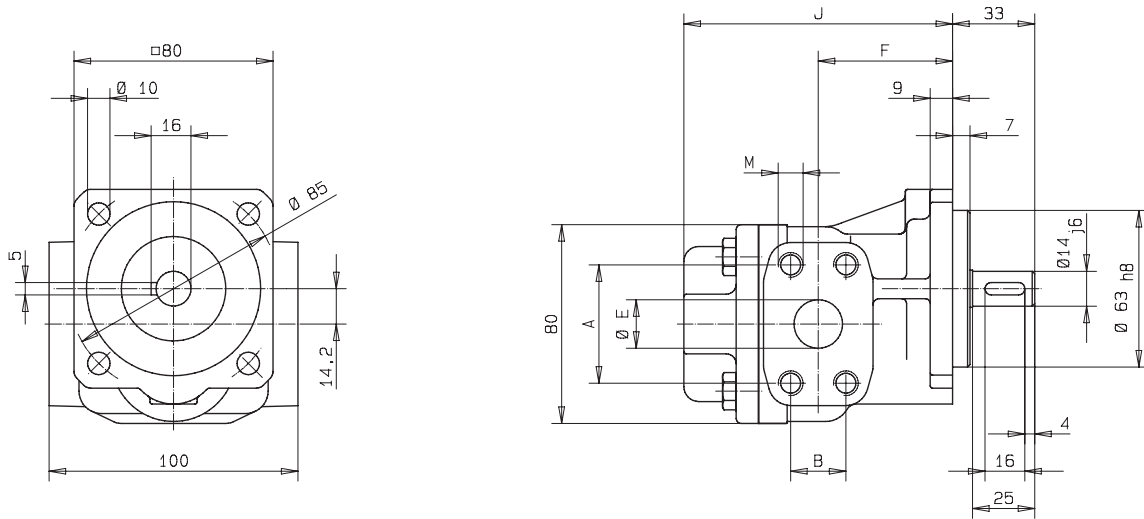

KF 4... 25 with pressure relief valve

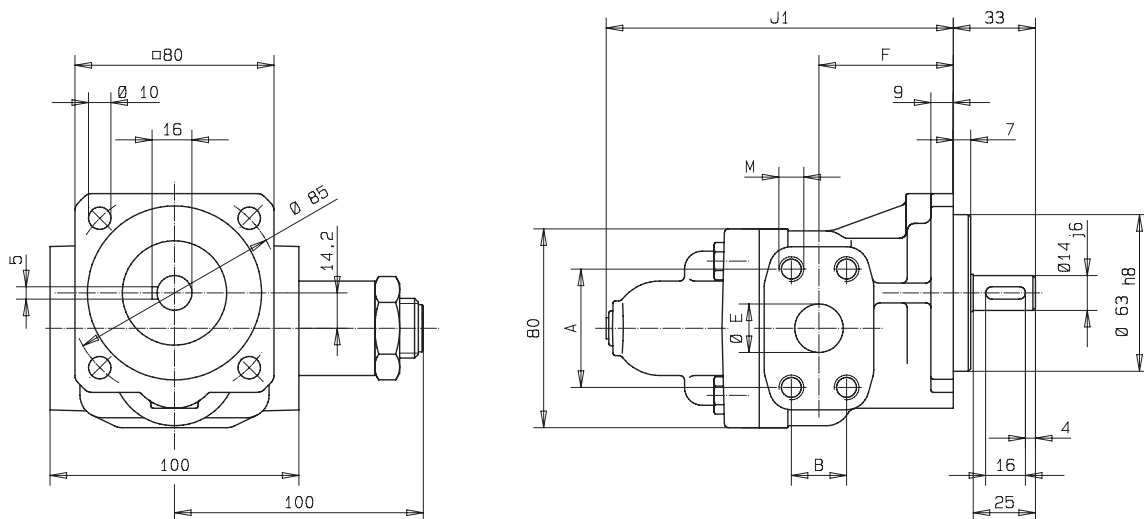

Nominal size	Suction and pressure connection								Weight in kg	
		A	B	E	M	F	J	J ₁	without valve	with valve
4...12	SAE 3/4	47.6	22.2	19.5	M10 15 deep	54	109	140	4.2	5.0
16...25	SAE 1	52.4	26.2	25	M10 17 deep	63	131	162	4.8	5.6

(Dimensions in mm)

Flange-Mounting with SAE 1 1/2-Connection

KF 32... 80

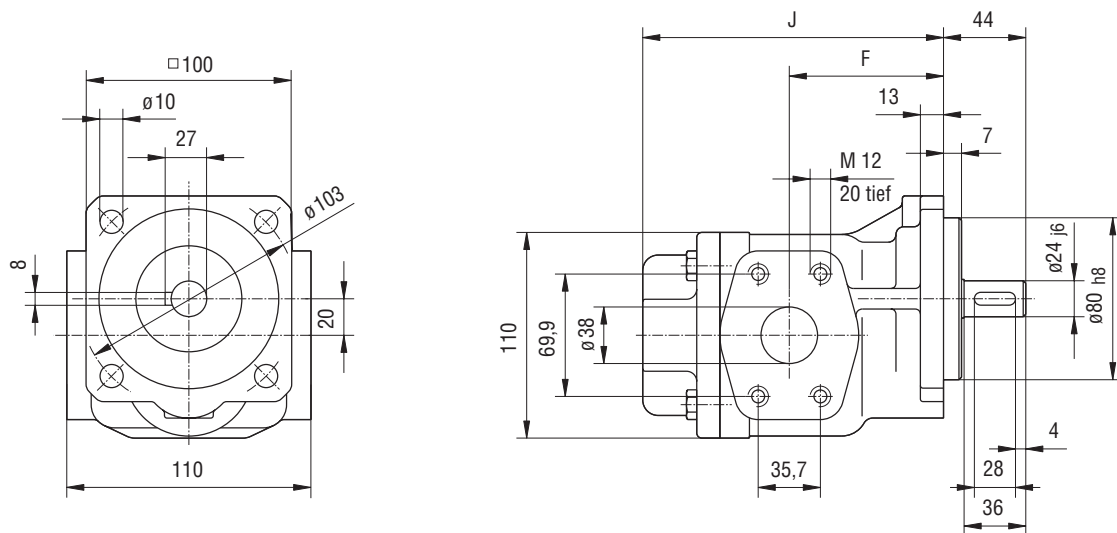

KF 32... 80 with pressure relief valve

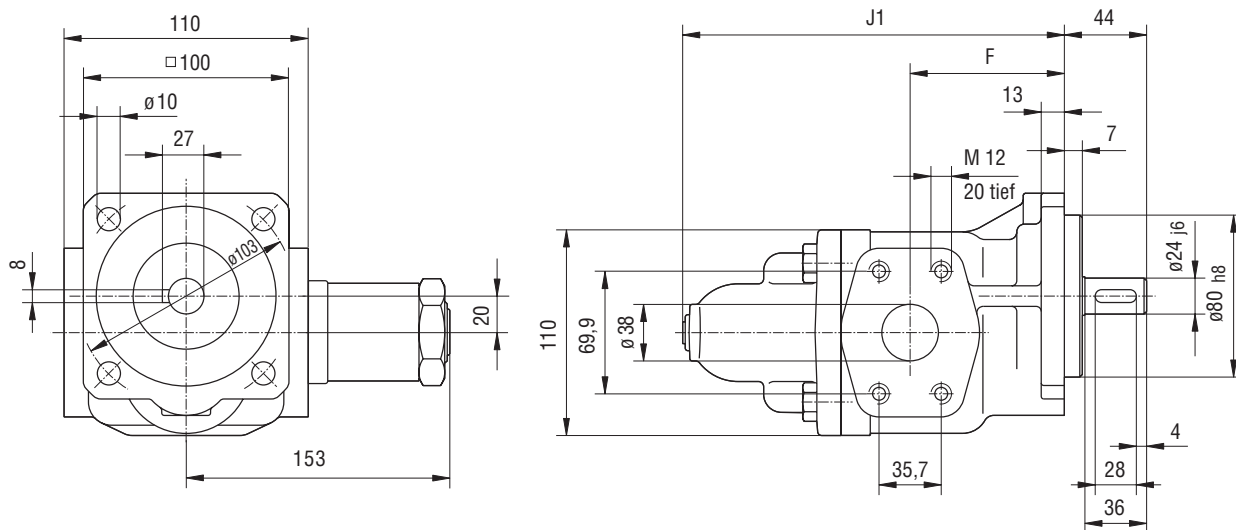

Nominal size		F	J	J ₁	Weight in kg	
					without valve	with valve
32...50	SAE 1 1/2	84	173	212	7.7	9.5
63 / 80	SAE 1 1/2	100	208	247	9.4	11.2

(Dimensions in mm)

Flange-Mounting Version with SAE 2-Connection (Special No. 232)

KF 50... 80

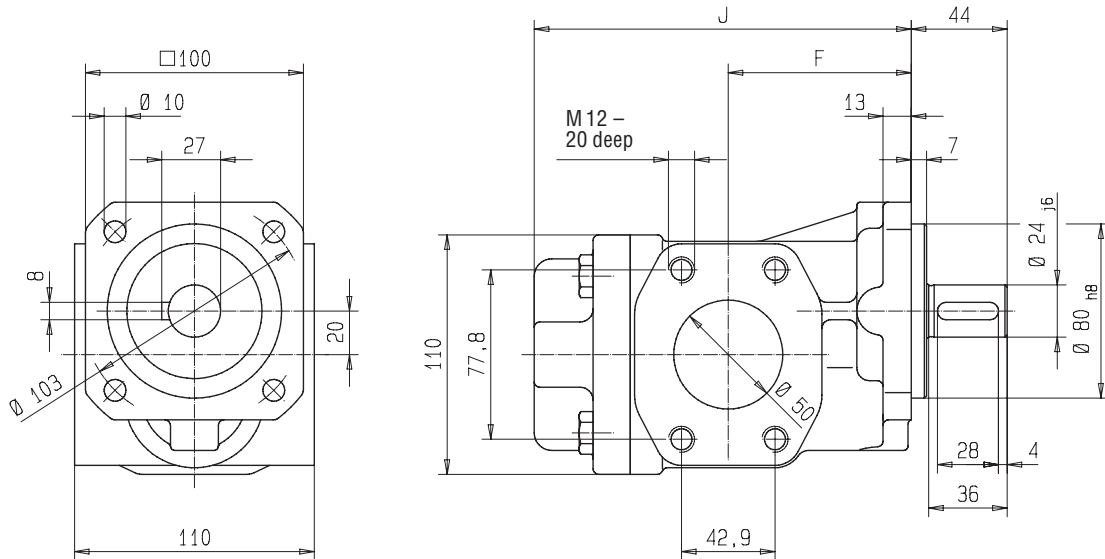

KF 50... 80 with pressure relief valve

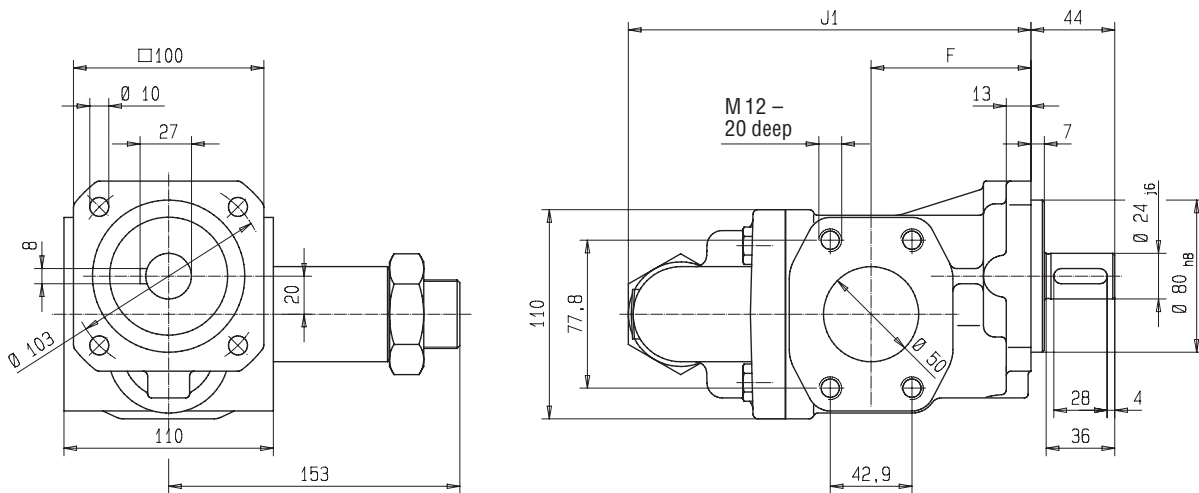

Nominal size		F	J	J ₁	Weight in kg	
					without valve	with valve
50	SAE 2	84	121	212	7.7	9.5
63/80	SAE 2	100	206	217	9.4	11.2

(Dimensions in mm)

Flange-Mounting Version with SAE 2-Connection

KF 100/112

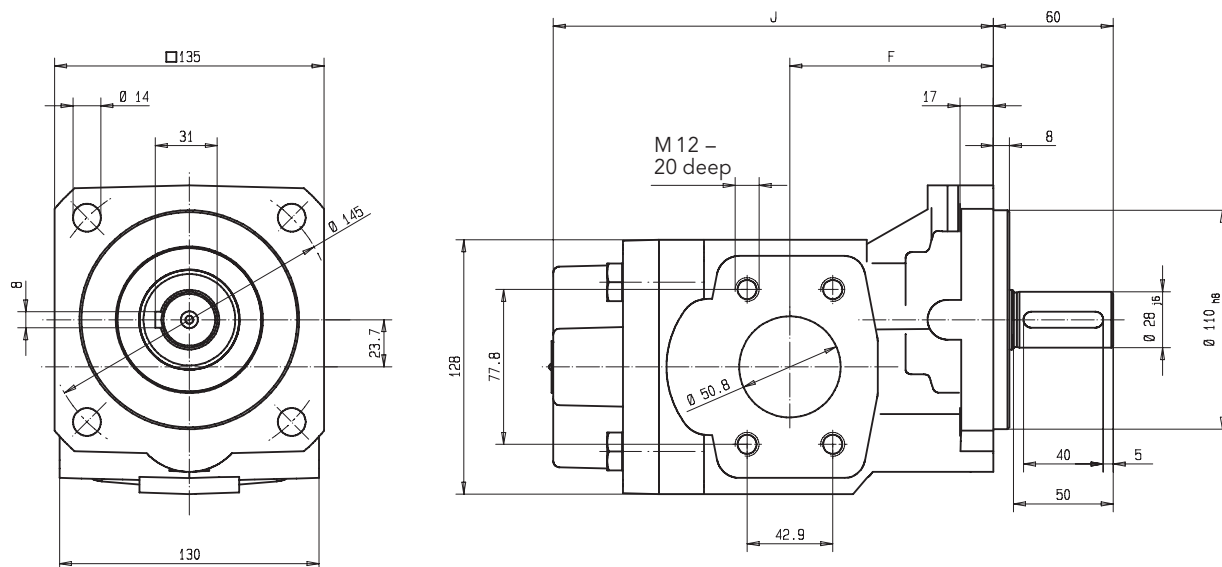

KF 100/112 with pressure relief valve

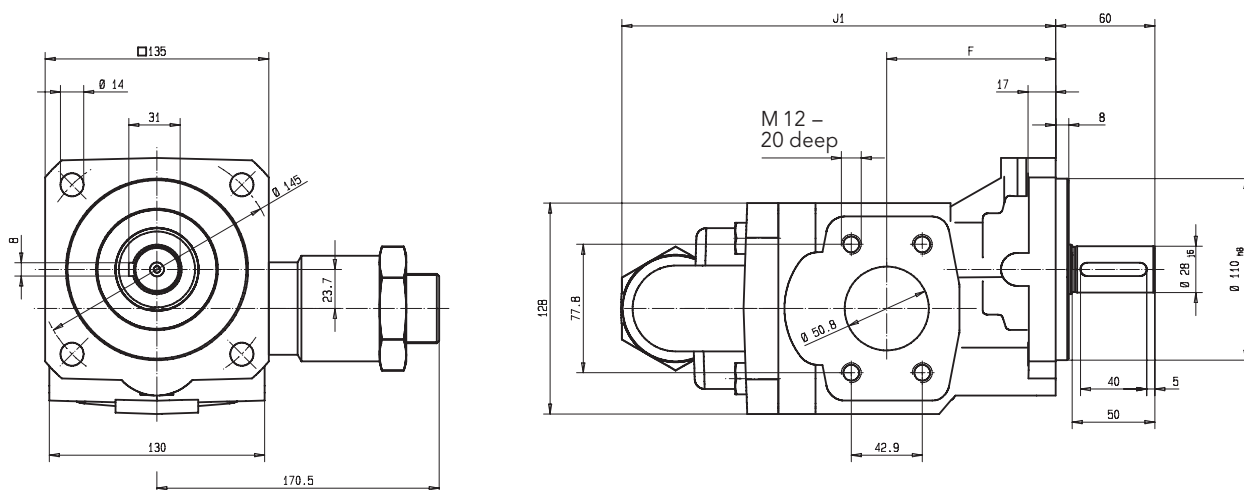

Nominal size		F	J	J ₁	Weight in kg	
					without valve	with valve
100/112	SAE 2	102	220.5	262.5	15.8	18.9

(Dimensions in mm)

Flange-Mounting Version with SAE 2 1/2-Connection (Special No. 232)

KF 100/112

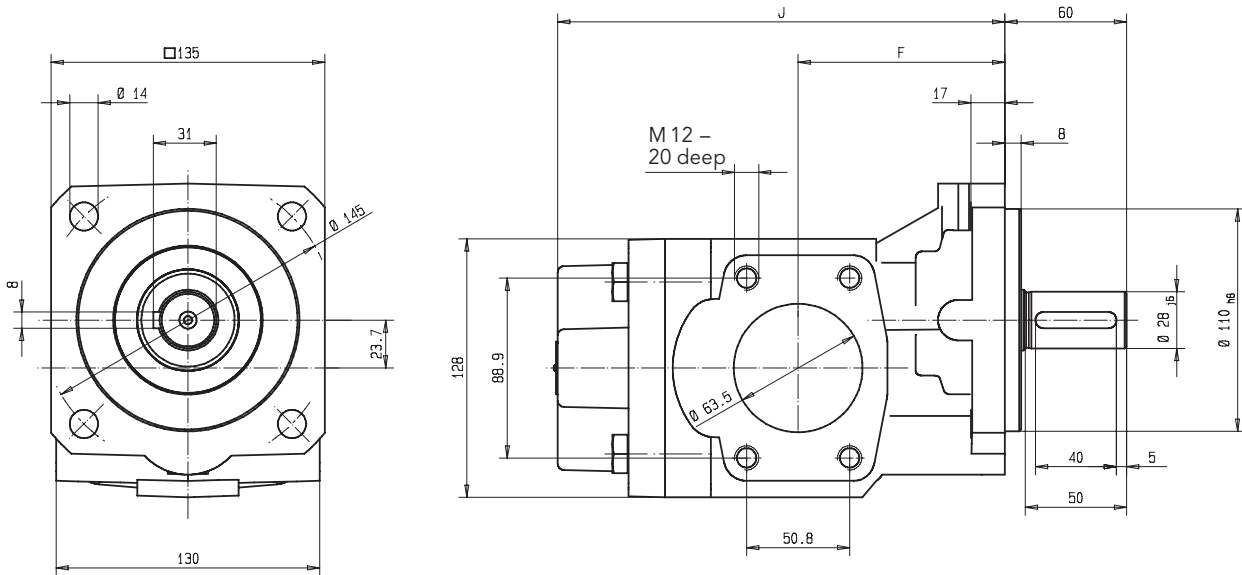

KF 100/112 with pressure relief valve

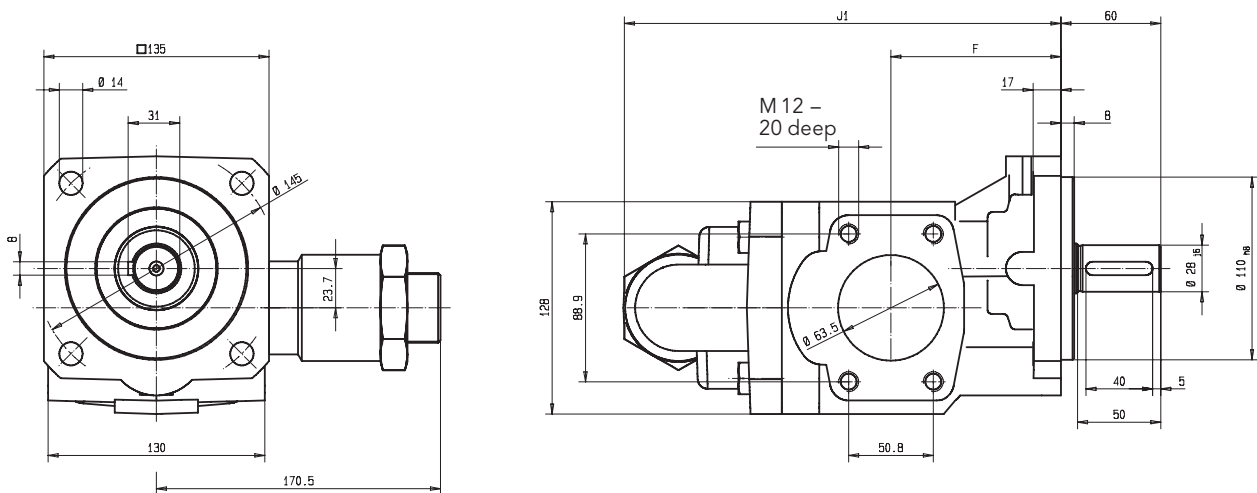

Nominal size		F	J	J ₁	Weight in kg	
					without valve	with valve
100/112	SAE 2 1/2	102	220.5	262.5	15.8	18.9

(Dimensions in mm)

Flange-Mounting Version with SAE 2-Connection (Sealing 31)

KF 100/112

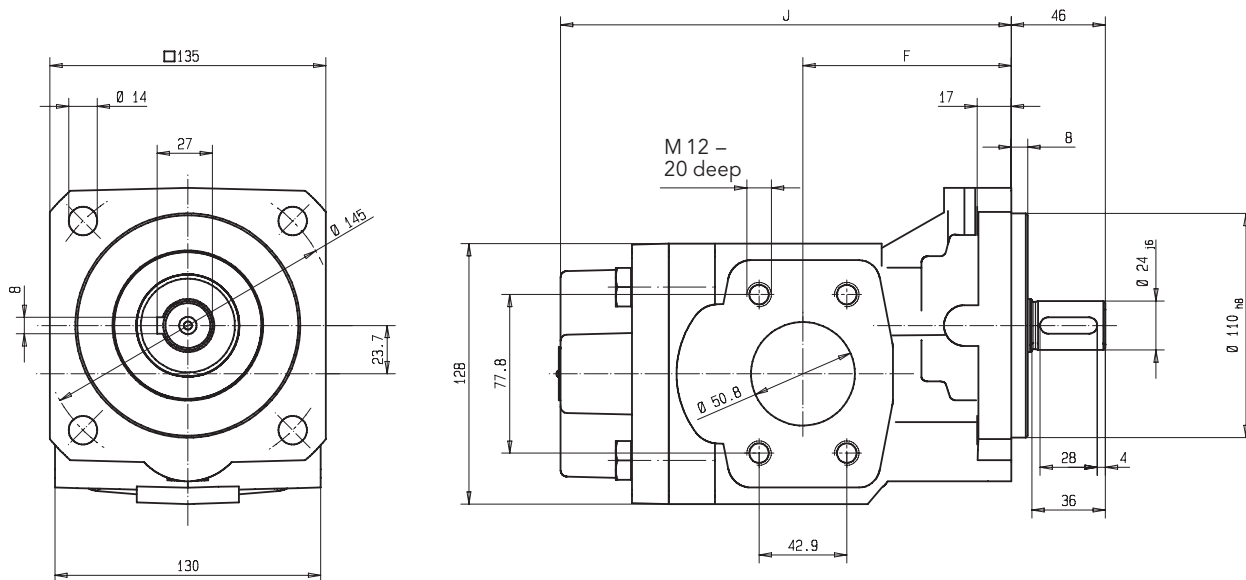

KF 100/112 with pressure relief valve

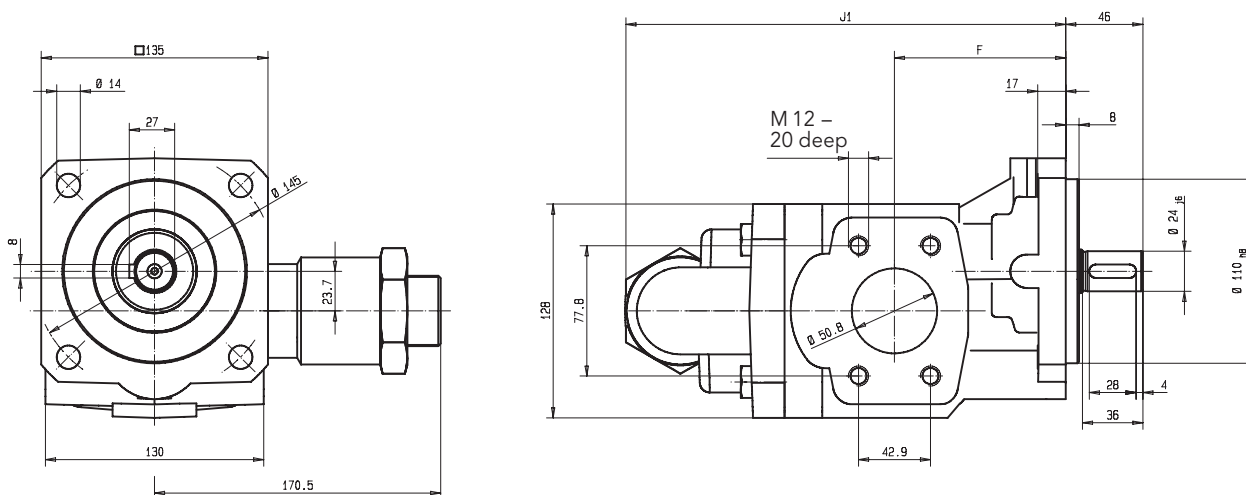

Nominal size		F	J	J ₁	Weight in kg	
					without valve	with valve
100/112	SAE 2	102	220.5	262.5	15.9	19.0

(Dimensions in mm)

Flange-Mounting Version with SAE 2½-Connection (Special No. 232 / Sealing 31)

KF 100/112

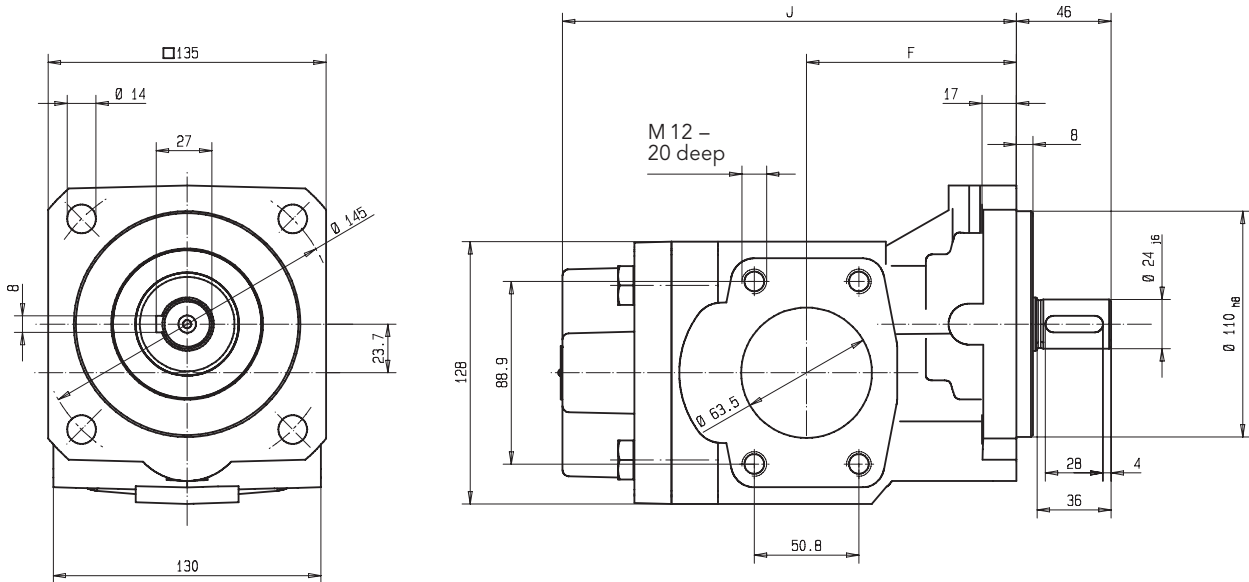

KF 100/112 with pressure relief valve

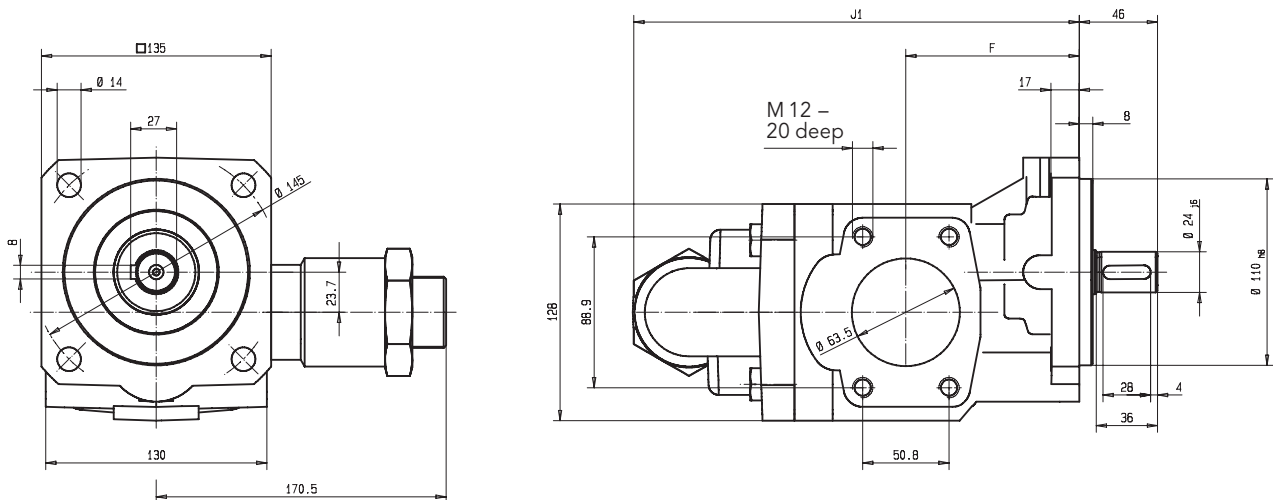

Nominal size		F	J	J ₁	Weight in kg	
					without valve	with valve
100/112	SAE 2½	102	220.5	262.5	15.9	19.0

(Dimensions in mm)

Pump with Mounting Angle, Pipe Thread

KF 4... 25

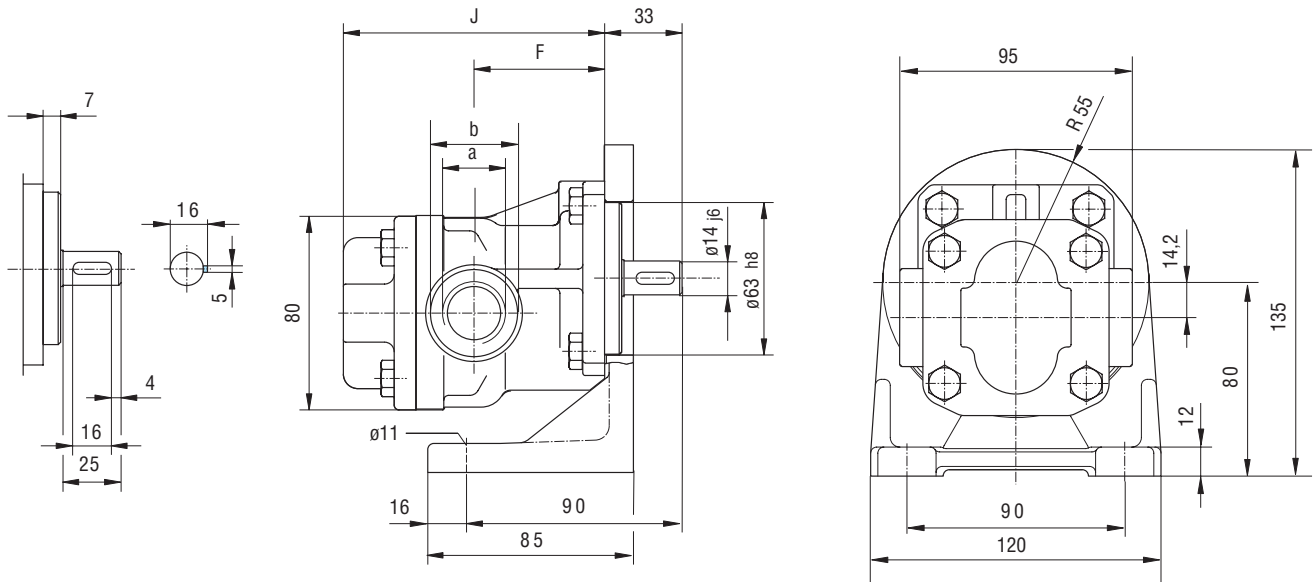

KF 4... 25 with pressure relief valve

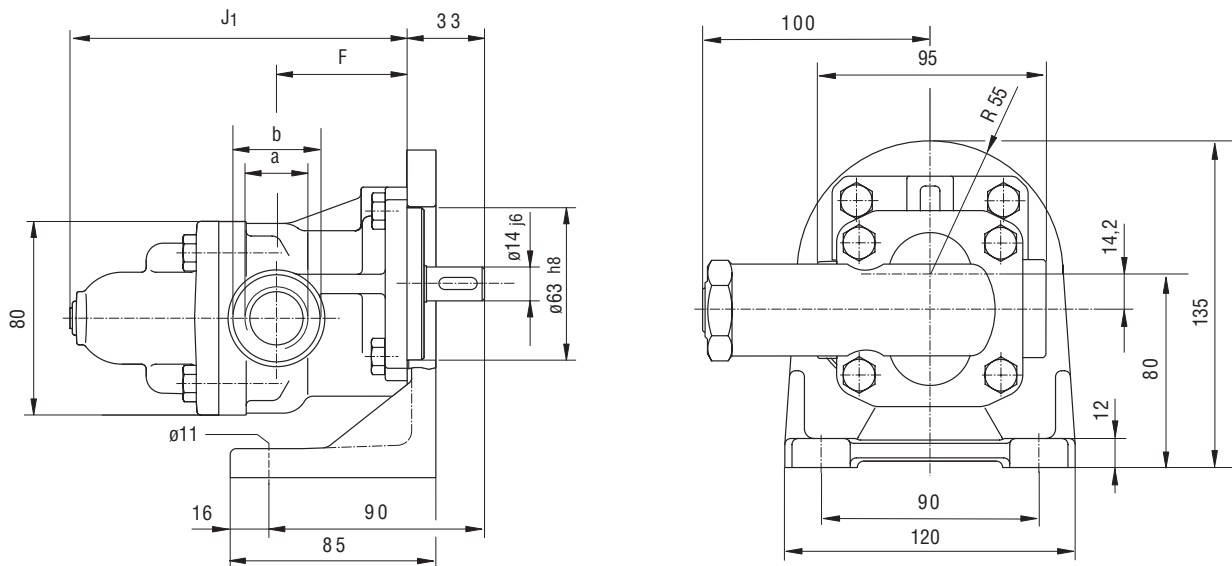

Nominal size	Suction and pressure connection		F	J	J ₁	Weight in kg	
	a	b				without valve	with valve
4...12	G 3/4 17 deep	Ø 36	54	109	140	4.2	5.0
16...25	G 1 19 deep	Ø 42	63	131	161	4.8	5.6

(Dimensions in mm)

Pump with Mounting Angle, SAE 1½-Connection

KF 32... 80

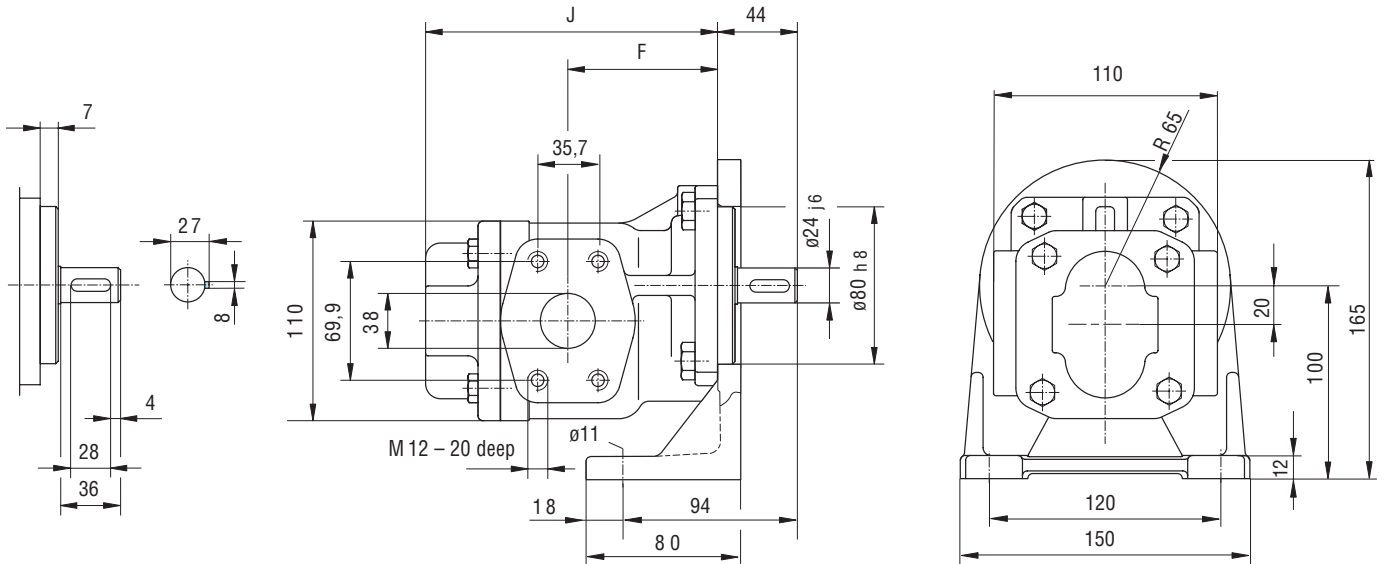

KF 32... 80 with pressure relief valve

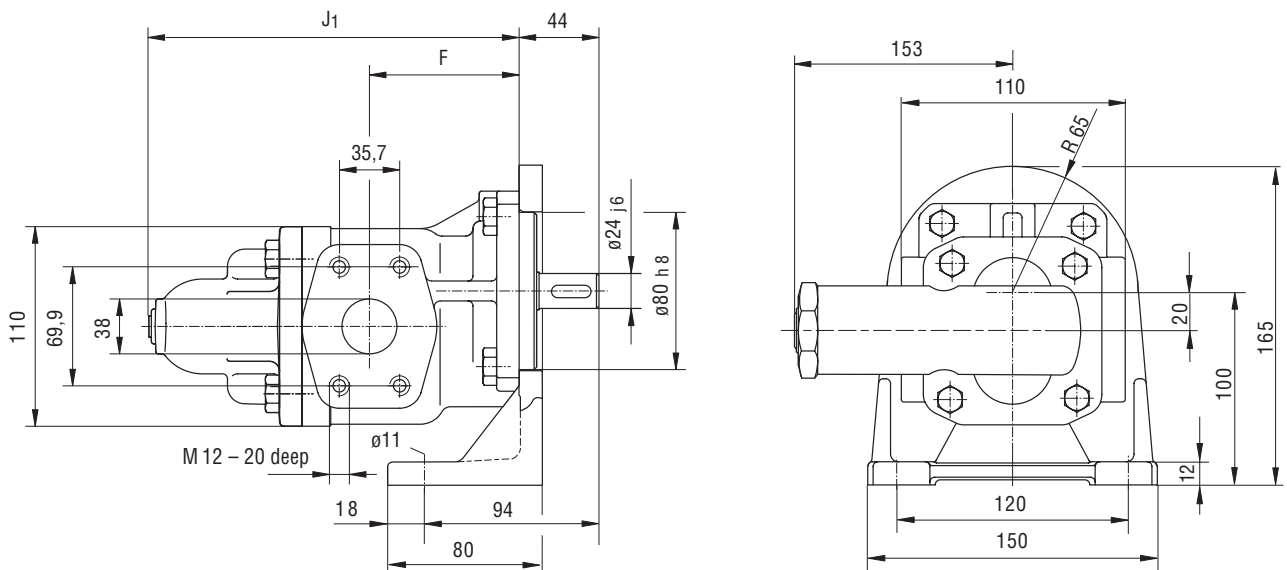

Nominal size		F	J	J ₁	Weight in kg	
					without valve	with valve
32...50	SAE 1½	84	173	212	9.5	11.3
63 / 80	SAE 1½	100	208	247	11.2	13.0

(Dimensions in mm)

Flange-Mounting Version with Universal Arrangement

KF 4... 25

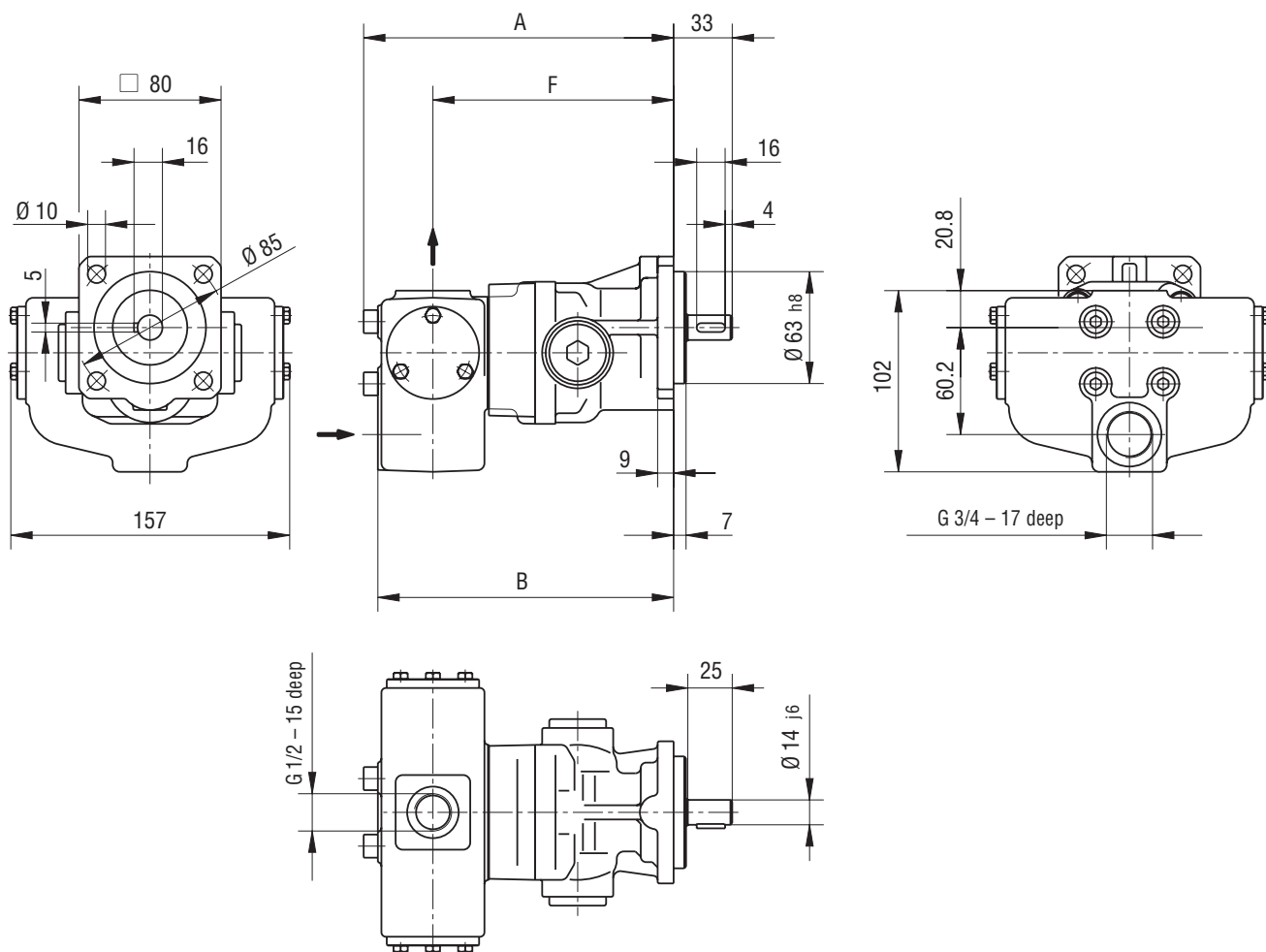

Ordering code

KF . UF .

Seals $\frac{1}{2}$

Nominal size	A	B	F	Weight in kg	Perm. manometr. low pressure at the pump suction connection p_e bar
4	174.5	166.5	135.5	6.9	0.35
5					
6					
8					
10					
12					
16	196.5	188.5	157.5	7.5	0.35
20					
25					

(Dimensions in mm)

Flange-Mounting Version with Universal Arrangement

KF 32...80

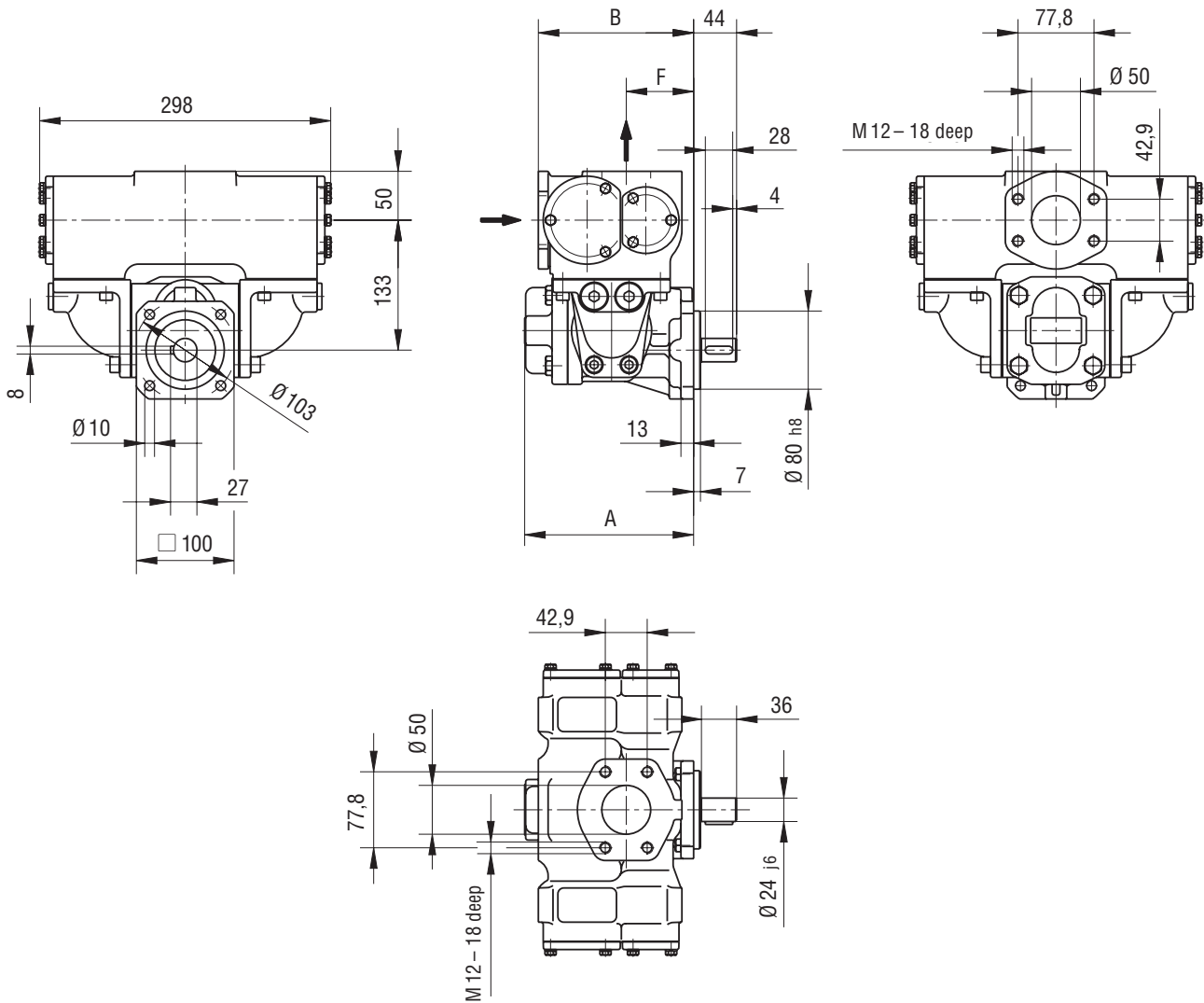

Ordering code

KF . UF .

Seals $\begin{matrix} 1 \\ 2 \end{matrix}$

Nominal size	A	B	F	Weight in kg	Perm. manometr. low pressure at the pump suction connection p_e bar
32	173	159	69	27.5	0.35
40					
50					
63	208	175	85	29.5	
80					

(Dimensions in mm)

Accessory Couplings

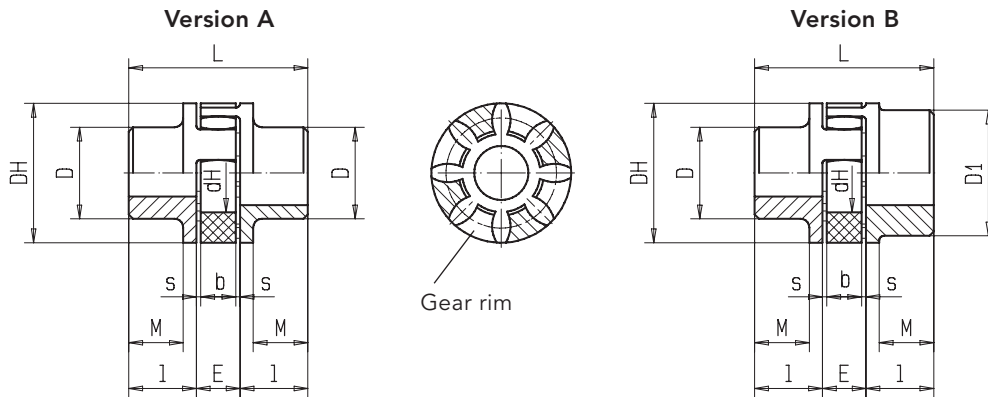

	Ordering code	Coupling size	Weight kg	Moment of inertia kgm ²	Pre bore		Finished bore		Dimensions (in mm)											
					part 1	part 2	part 1	part 2	l	E	s	b	L	M	DH	D	D ₁	dh		
Version A	RA 19-Z25/...-Z25/..	19	0.117	0.00003	4	-	6	-	19	-	25	16	2	12	66	20	40	32	-	18
	RA 24-Z30/...-Z30/..	24	0.24	0.00008	6	-	8	-	24	-	30	18	2	14	78	24	55	40	-	27
	RA 28-Z30/...-Z30/..	28	0.39	0.0002	8	-	10	-	28	-	30	20	2.5	15	90	28	65	48	-	30
Version B	RA 19/24-Z25/...-Z25/..	19/24	0.129	0.00004	4	17	6	19	19	24	25	16	2	12	66	20	40	32	-	18
	RA 24/28-Z30/...-Z30/..	24/28	0.26	0.0001	6	22	8	24	24	28	30	18	2	14	78	24	55	40	-	27
	RA 28/38-Z35/...-Z35/..	28/38	0.46	0.0003	8	26	10	28	28	38	35	20	2.5	15	90	28	65	48	-	30
	RA 38/45-Z45/...-Z45/..	38/45	0.89	0.0008	10	36	12	38	38	45	45	24	3	18	114	37	80	66	-	38
	RA 42/55-Z50/...-Z50/..	42/55	1.39	0.0018	12	40	14	42	42	55	50	26	3	20	126	40	95	75	-	46
	RG 42/55-Z50/...-Z75/..	42/55	3.57	0.005	12	40	14	42	42	55	50/75	26	3	20	126	40	95	75	-	46

Type Key KF Coupling

Ordering example

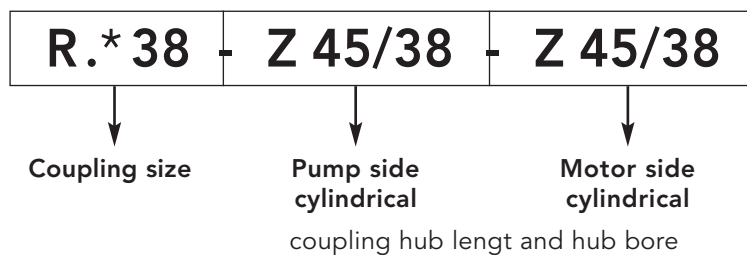

.*	Hub material
A	AL
G	GG

Working temperature:
 -20 °C to +80 °C (-4 °F to 176 °F)
 (short duration temperature peaks up to 120 °C / 248 °F are permissible).

Weights and mass moments of inertia refer to max. finish machined bore without slot.
 Finish-machined bores to ISO Fit H7, parallel key slots in accordance with DIN 6886 Sh.1.

Bell Housing

KF 4... 25 Aluminum bell housing

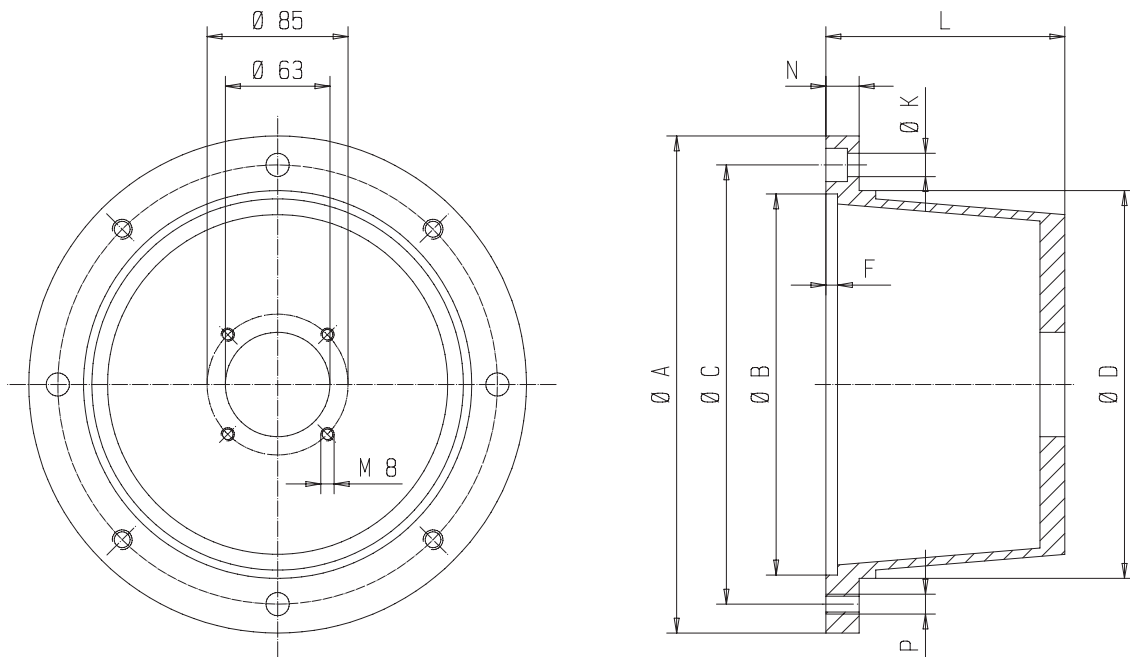

Size	Bell housing	Coupling	Dimensions (in mm)									Weight
			A	B	C	D	F	K	L	N	P	kg
71 S	PT160-A-063-80	RA19-Z25/14-Z25/14	160	110	130	110	7	9	80	13	M8	1,01
71												
80 S	PT200-A-063-100	RA19-Z25/14-Z25/19	200	130	165	145	7	11	100	16	M10	1,06
80												
90 S	PT200-A-063-100	RA19/24-Z25/14-Z25/24	200	130	165	145	7	11	100	16	M10	1,06
90 L												
100 LS	PT250-A-063-120	RA24/28-Z30/14-Z30/28	250	180	215	190	7	14	120	19	M12	1,75
100 L												
112 M												

Bell Housing

KF 32...80 Aluminum bell housing

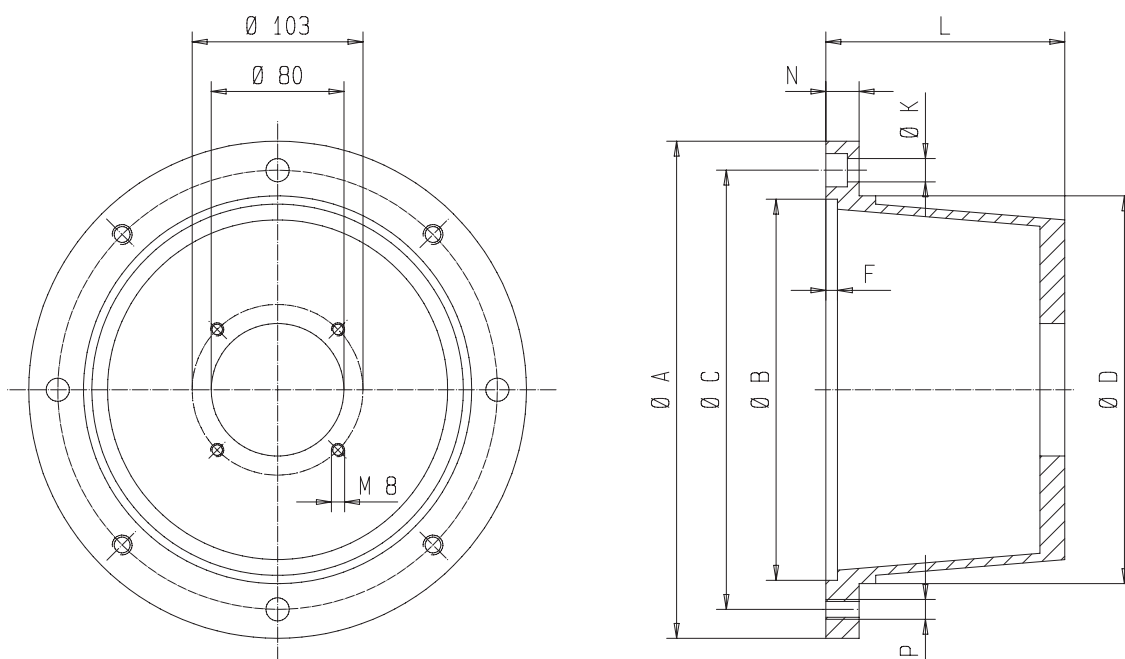

Size	Bell housing	Coupling	Dimensions (in mm)									Weight kg
			A	B	C	D	F	K	L	N	P	
80 S	PT200-A-080-100	RA19/24-Z25/24-Z25/19	200	130	165	145	7	11	100	16	M10	1.41
80												
90 S	PT200-A-080-110	RA24-Z30/24-Z30/24	200	130	165	145	7	11	110	16	M10	1.19
90 L												
100 LS	PT250-A-080-124	RA24/28-Z30/24-Z30/28	250	180	215	190	7	14	124	19	M12	1.42
100 L												
112 M												
132 S	PT300-A-080-144	RA28/38-Z35/24-Z35/38	300	230	265	234	7	14	144	20	M12	2.10
132 M												
160 M	PT350-A-080-188	RA38/45-Z45/24-Z45/42	350	250	300	260	7	18	188	26	M16	3.05
160 L												

Bell Housing

KF 100/112 Aluminum bell housing

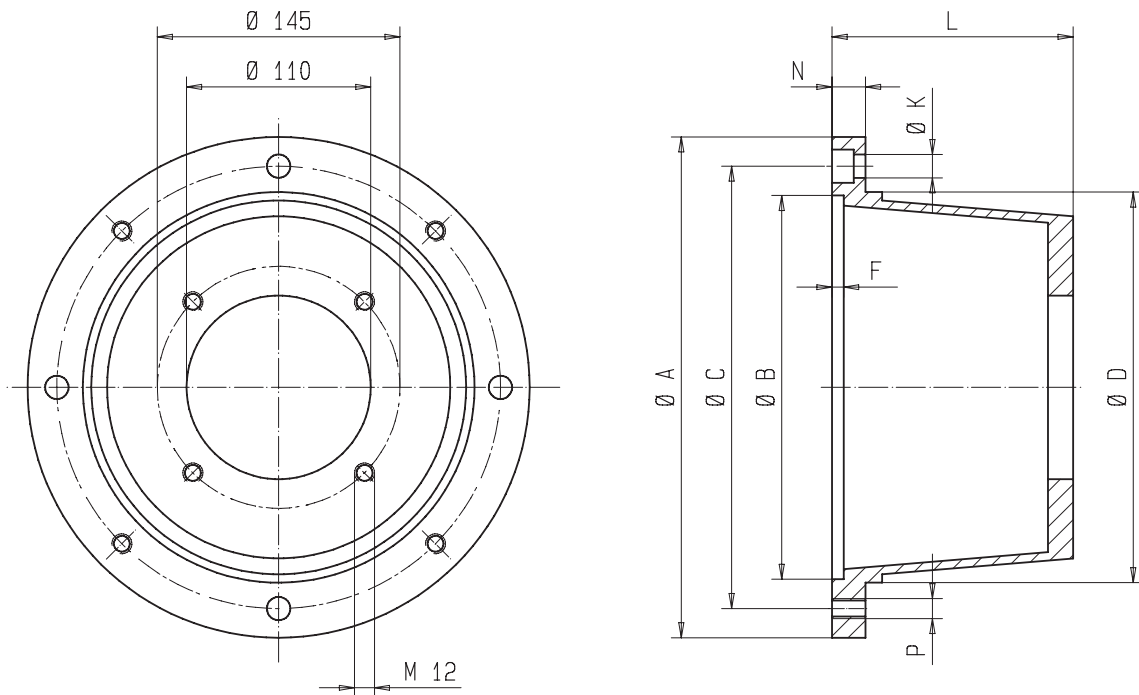

Size	Bell housing	Coupling	Dimensions (in mm)									Weight kg
			A	B	C	D	F	K	L	N	P	
100 L	PT250-A-110-135	RA24/28-Z30/28-Z30/28	250	180	215	190	7	14	135	18	M12	1.4
112 M		* RA24/28-Z30/24-Z30/28										
132 S	PT300-A-110-168	RA28/38-Z35/28-Z35/38	300	230	265	234	7	14	168 * 144	20	M12	2.0 * 1.6
132 M	* PT300-A-110-144	* RA28/38-Z35/24-Z35/38										
160 M	PT350-A-110-188	RA38/45-Z45/28-Z45/42	350	250	300	260	7	18	188	26	M16	2.9
160 L		* RA38/45-Z45/24-Z45/42										
180 M	PT350-A-110-204	RA42/55-Z50/28-Z50/48	350	250	300	260	7	18	204	26	M16	3.0
180 L		* RG42/55-Z50/24-Z75/48										

* Version sealing 31

Motor-Pump Assemblies with Pipe Thread

KF 4... 25

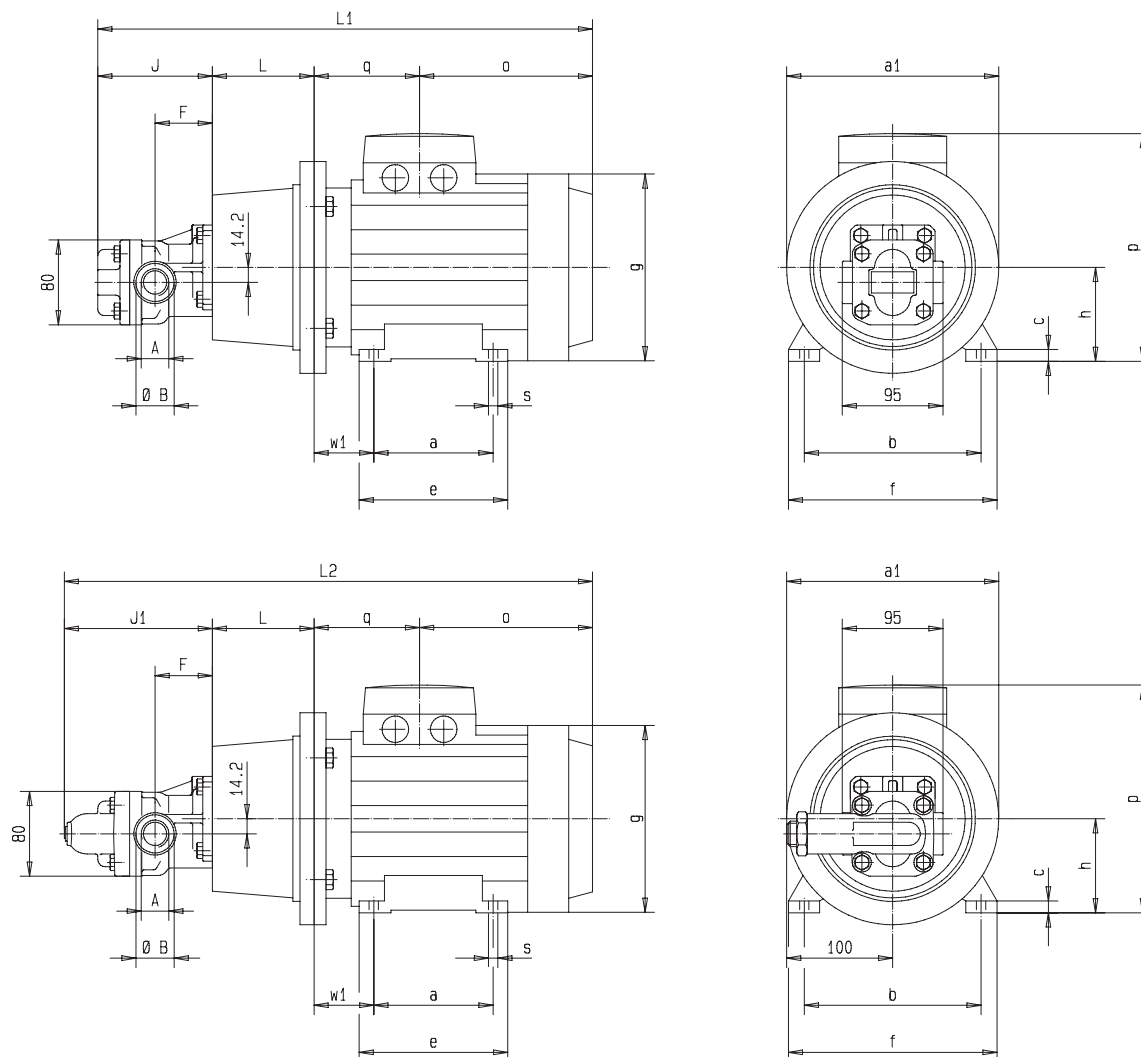

with pressure relief valve

KF 4... 25 Pump sizes (in mm)

Nominal size	Suction and pressure connection		F	J	J ₁
	A	B			
4...12	G 3/4 17 deep	Ø 36	54	109	140
16...25	G 1 19 deep	Ø 42	63	131	162

Motor-Pump Assemblies with Pipe Thread

KF 4 ... 25

Frame size	Power Motor 6 pole		Power Motor 4 pole		Bell housing	Coupling	Total weight * kg	
	kW	1/min	kW	1/min			Nominal size 4...12 16...25	
71 S	0.18	920	0.25	1400	PT160-A-063-80	RA19-Z25/14-Z25/14	10	10.5
71	0.25	920	0.37	1410			11	11.5
80 S	0.37	920	0.55	1420	PT200-A-063-100	RA19-Z25/14-Z25/19	13.5	14
80	0.55	930	0.75	1420			14.5	15
90 S	0.75	930	1.1	1410	PT200-A-063-100	RA19/24-Z25/14-Z25/24	17.5	18
90 L	1.1	930	1.5	1420			20.5	21
100 LS	–	–	2.2	1430	PT250-A-063-120	RA24/28-Z30/14-Z30/28	26.5	27
100 L	1.5	950	3	1430			29.5	30
112 M	2.2	940	4	1435			32.5	33

* with pressure relief valve add, weight 0.8 kg

KF 4 ... 25 Dimensions

Frame size	Dimensions (in mm)																	
	4...12		16...25		4 ... 25													
	L ₁ *	L ₁ *	L ₂ *	L ₂ *	L	a ₁	a	b	c*	e*	f*	g*	h	o*	p*	q*	ø s*	w ₁
71 S	397	419	428	450	80	160	90	112	9	112	136	130	71	127	176	81	7	45
71	397	419	428	450	80	160	90	112	9	112	136	130	71	127	176	81	7	45
80 S	434	456	465	487	100	200	100	125	10	125	154	150	80	138	190	87	10	50
80	434	456	465	487	100	200	100	125	10	125	154	150	80	138	190	87	10	50
90 S	466	488	472	494	100	200	100	140	10	125	170	177	90	134	217	99	10	56
90 L	466	488	497	519	100	200	125	140	10	150	170	177	90	159	217	99	10	56
100 LS	518	540	549	571	120	250	140	160	12	172	197	197	100	187	237	102	12	63
100 L	518	540	549	571	120	250	140	160	12	172	197	197	100	187	237	102	12	63
112 M	530	552	561	583	120	250	140	190	12	168	222	221	112	161	258	140	12	70

Note

* Dimensions dependent on motor typ (drawing: manufacture ABB).
Other manufactures motors can be supplied on request.
Motor frame sizes are based on DIN 42673/677.

All pump and motor sizes can be combined.

Motor-Pump Assemblies with SAE 1 1/2-Connection

KF 32... 80

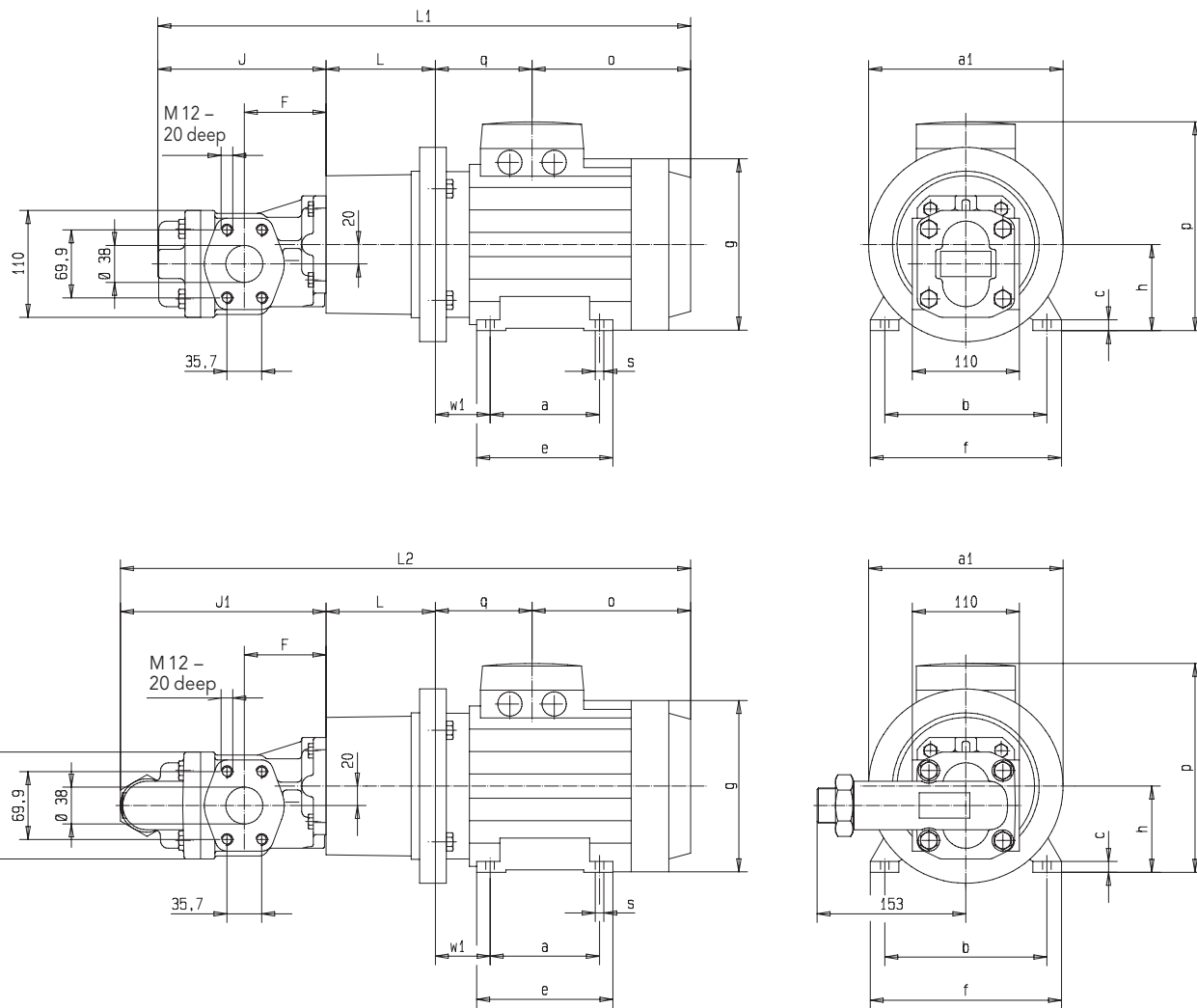

with pressure relief valve

KF 32... 80 Pump sizes (in mm)

Nominal size	F	J	J ₁
32...50	84	173	212
63 / 80	100	208	247

Motor-Pump Assemblies with SAE 1 1/2-Connection

KF 32... 80

Frame size	Power Motor 6 pole		Speed Motor 4 pole		Bell housing	Coupling	Total weight * kg	
	kW	1/min	kW	1/min			Nominal size 32...50 63...80	
80 S	0.37	920	0.55	1420	PT200-A-080-100	RA19/24-Z25/24-Z25/19	18.4	20.1
80	0.55	930	0.75	1420			19.4	21.1
90 S	0.75	930	1.1	1410	PT200-A-080-110	RA24-Z30/24-Z30/24	22.3	24
90 L	1.1	930	1.5	1420			25.3	27
100 LS	–	–	2.2	1430	PT250-A-080-124	RA24/28-Z30/24-Z30/28	31.3	33
100 L	1.5	950	3	1430			34.3	36
112 M	2.2	940	4	1435			37.3	39
132 S	3	960	5.5	1450	PT300-A-080-144	RA28/38-Z35/24-Z35/38	50	52
132 M	4	960	7.5	1450			58	60
132 M	5.5	955	–	–			64	66
160 M	7.5	975	11	1455	PT350-A-080-188	RA38/45-Z45/24-Z45/42	91	93
160 L	11	970	15	1460			105	107

* with pressure relief valve add. weight 1.8 kg

KF 32... 80 Dimensions

Frame size	Dimensions (in mm)																	
	32...50 63...80				32 - 80													
	L ₁ *	L ₁ *	L ₂ *	L ₂ *	L	a ₁	a	b	c*	e*	f*	g*	h	o*	p*	q*	ø s*	w ₁
80 S	498	533	537	572	100	200	100	125	10	125	154	150	80	138	190	87	10	50
80	498	533	537	572	100	200	100	125	10	125	154	150	80	138	190	87	10	50
90 S	515	550	554	589	110	200	100	140	10	125	170	177	90	134	217	99	10	56
90 L	540	575	579	614	110	200	125	140	10	150	170	177	90	159	217	99	10	56
100 LS	586	621	625	660	124	250	140	160	12	172	197	197	100	187	237	102	12	63
100 L	586	621	625	660	124	250	140	160	12	172	197	197	100	187	237	102	12	63
112 M	598	633	637	672	124	250	140	190	12	168	222	221	112	161	258	140	12	70
132 S	684	719	723	758	144	300	140	216	14	212	262	261	132	216	296	151	12	89
132 M	684	719	723	758	144	300	178	216	14	212	262	261	132	216	296	151	12	89
160 M	854	889	893	928	188	350	210	254	20	288	310	310	160	299	370	194	15	108
160 L	854	889	893	928	188	350	254	254	20	288	310	310	160	299	370	194	15	108

Note

* Dimensions dependent on motor typ (drawing: manufacture ABB).

All pump and motor sizes can be combined.

Other manufactures motors can be supplied on request. Motor frame sizes are based on DIN 42673/677.

Motor-Pump Assemblies with SAE 2-Connection

KF 100/112

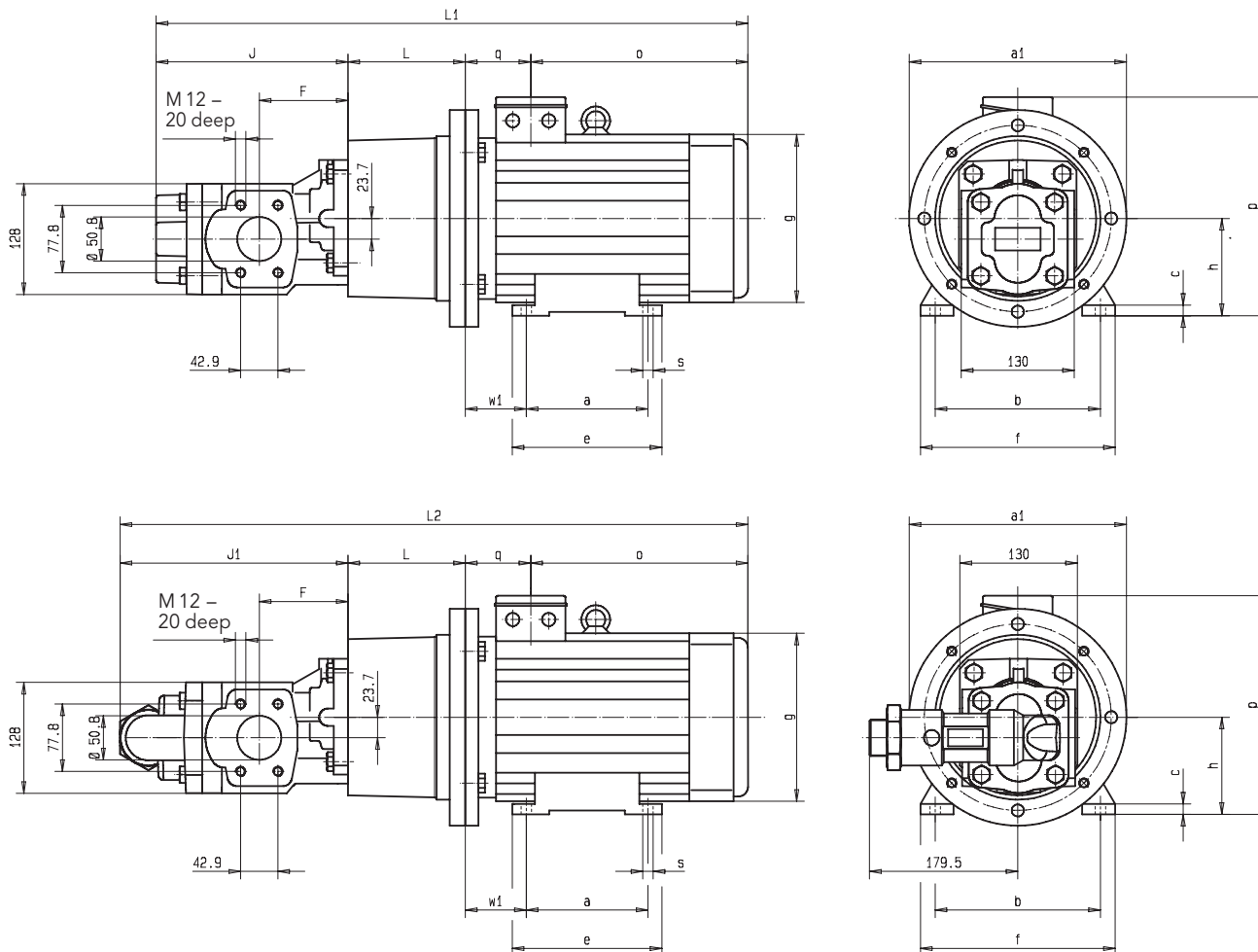

with pressure relief valve

KF 100/112 Pump sizes (in mm)

Nominal size	F	J	J ₁
100/112	102	220.5	262.5

Motor-Pump Assemblies with SAE 2-Connection

KF 100/112

Frame size	Power Motor 6 pole		Power Motor 4 pole		Bell housing	Coupling	Total weight * kg	
	kW	1/min	kW	1/min			Motor 6 pole	Motor 4 pole
100 LS	–	–	2.2	1430	PT250-A-110-135	RA24/28-Z30/28-Z30/28	–	72.2
100 L	1.5	940	3.0	1430			67.2	72.2
112 M	2.2	930	4.0	1425			72.2	74.2
132 S	3.0	955	5.5	1445	PT300-A-110-168	RA28/38-Z35/28-Z35/38	80.2	77.9
132 M	4.0	955	7.5	1445			80.2	77.9
160 M	7.5	960	11.0	1445	PT350-A-110-188	RA38/45-Z45/28-Z45/42	80.1	83.2
160 L	11.0	960	15.0	1455			80.1	83.2
180 M	–	–	18.5	1455	PT350-A-110-204	RA42/55-Z50/28-Z50/48	–	84.9
180 L	15.0	970	22.0	1460			81.9	85.8

* with pressure relief valve add, weight 5.7 kg

KF 100/112 Dimensions

Frame size	Dimensions (in mm)															
	100/112															
	L ₁ *	L ₂ *	L	a ₁	a	b	c*	e*	f*	g*	h	o*	p*	q*	ø s*	w1
100 LS	644.5	686.5	135	250	140	160	12	172	197	197	100	187	237	102	12	63
100 L	644.5	686.5	135	250	140	160	12	172	197	197	100	187	237	102	12	63
112 M	656.5	698.5	135	250	140	190	12	168	222	221	112	161	258	140	12	70
132 S	755.5	797.5	168	300	140	216	14	212	262	261	132	216	296	151	12	89
132 M	755.5	797.5	168	300	178	216	14	212	262	261	132	216	296	151	12	89
160 M	901.5	943.5	188	350	210	254	20	288	310	310	160	299	370	194	15	108
160 L	901.5	943.5	188	350	254	254	20	288	310	310	160	299	370	194	15	108
180 M	917.5	959.5	204	350	279	279	20	316	340	310	180	299	390	194	15	121
180 L	958.5	1000.5	204	350	279	279	20	316	340	310	180	340	390	194	15	121

Note

* Dimensions dependent on motor typ (drawing: manufacture ABB).
Other manufactures motors can be supplied on request.
Motor frame sizes are based on DIN 42673/677.

All pump and motor sizes can be combined.

Accessory Connections

Threaded Flange G-SAE 3/4

Welding Flange S-SAE 3/4

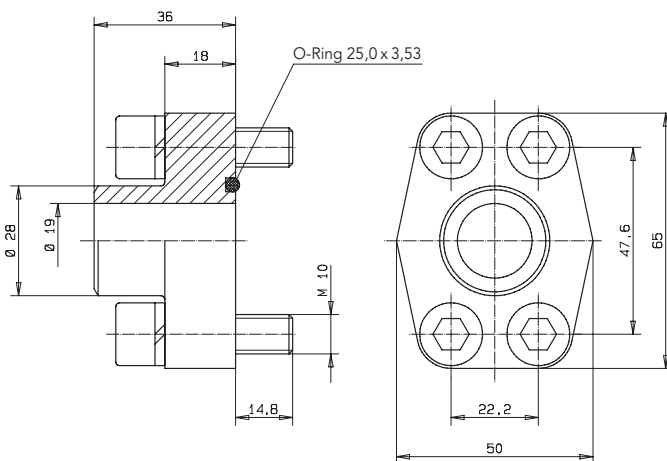
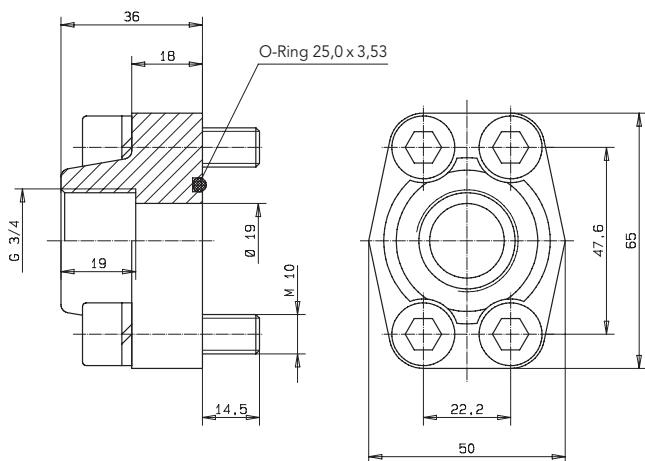

Weight 0.39 kg – N
 – F
 – P

Weight 0.39 kg – N
 – F
 – P

Threaded Flange G-SAE 1

Welding Flange S-SAE 1

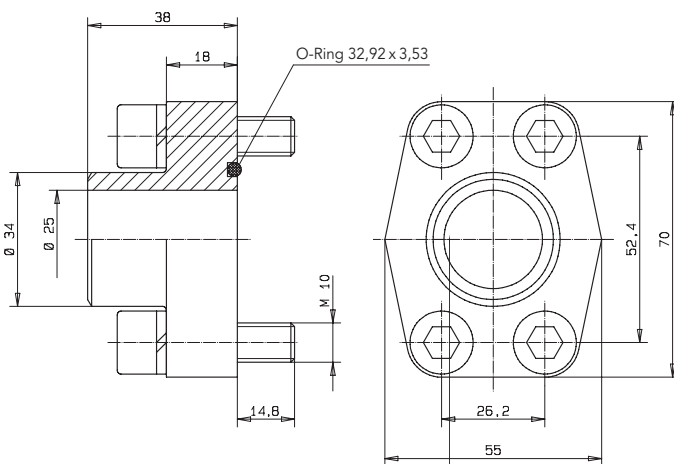
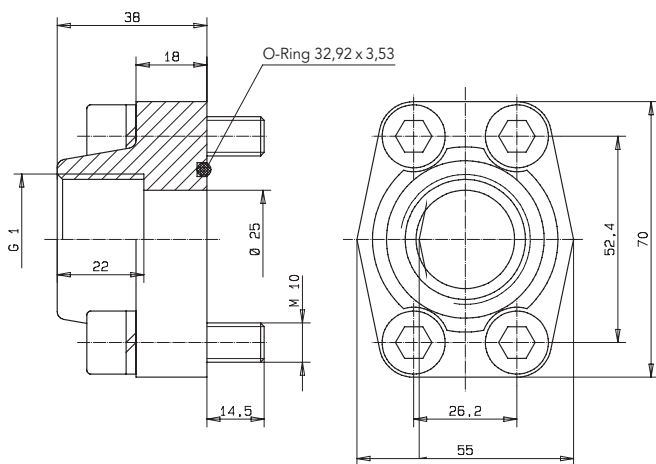

Weight 0.46 kg – N
 – F
 – P

Weight 0.46 kg – N
 – F
 – P

N = NBR O-Ring
 F = FKM O-Ring
 P = PTFE O-Ring

Accessory Connections

Threaded Flange G-SAE 1 1/2

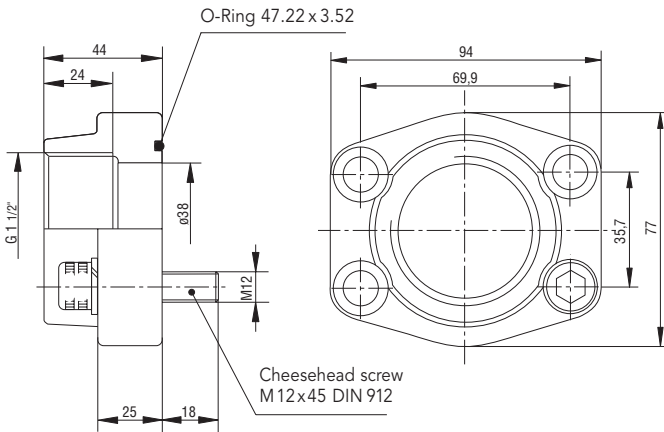

Weight 1.05 kg – N
 – F
 – P

Welding Flange S-SAE 1 1/2

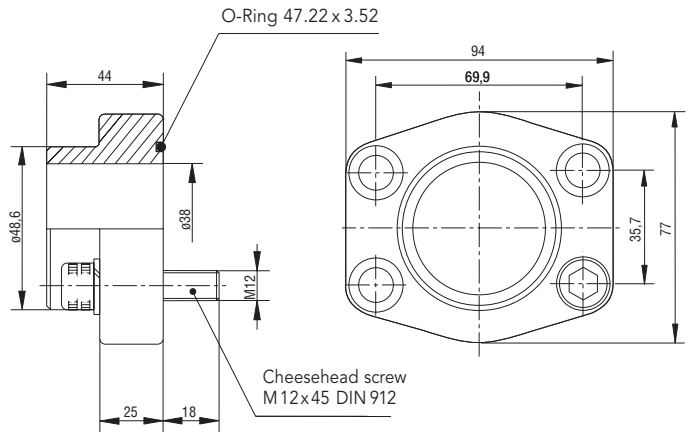

Weight 1.05 kg – N
 – F
 – P

Threaded Flange G-SAE 2

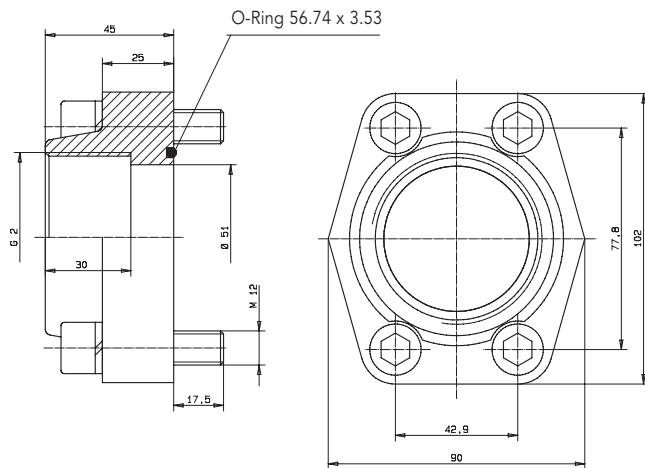

Weight 1.19 kg – N
 – F
 – P

Welding Flange S-SAE 2

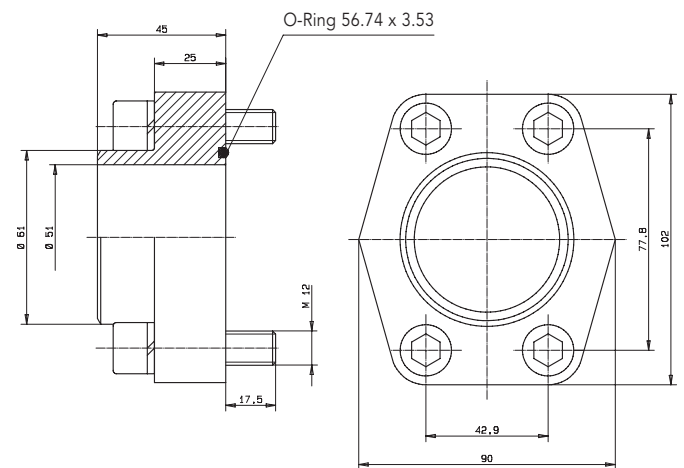

Weight 1.19 kg – N
 – F
 – P

N = NBR O-Ring
 F = FKM O-Ring
 P = PTFE O-Ring

Accessory Connections

Threaded Flange G-SAE 2 1/2

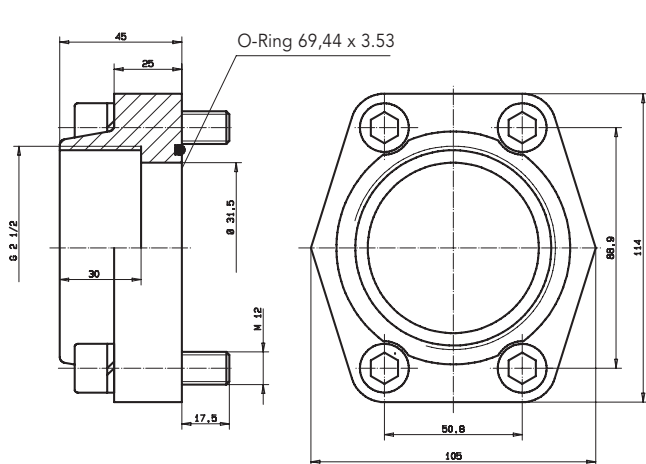

Weight 1.4 kg – N
 – F
 – P

Welding Flange S-SAE 2 1/2

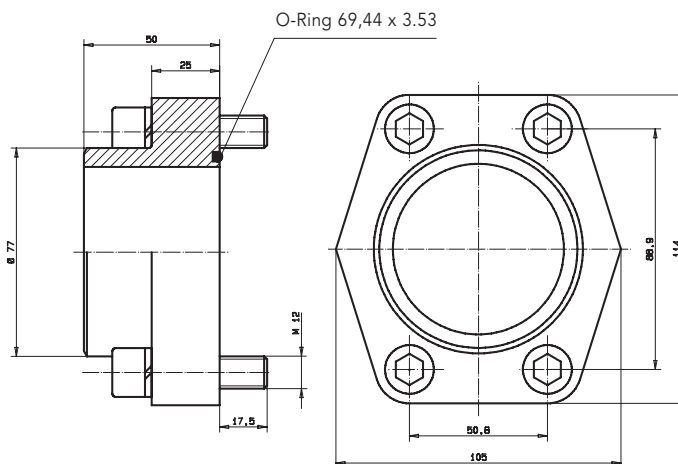

Weight 1.4 kg – N
 – F
 – P

N = NBR O-Ring
 F = FKM O-Ring
 P = PTFE O-Ring

Accessory Quench Chamber

Quench tank

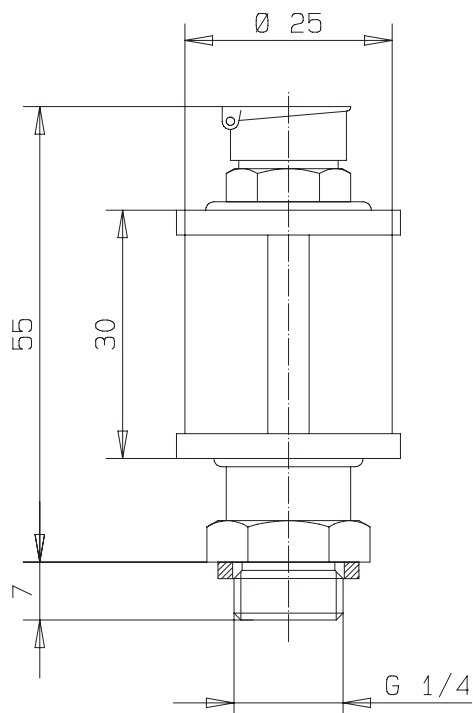

Adapter for screw size tap G 1/8

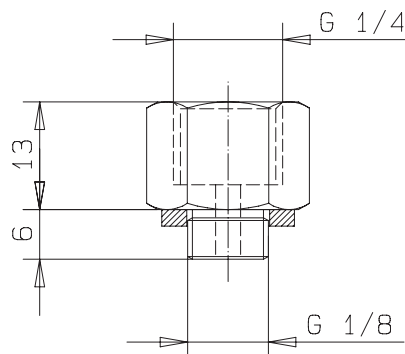

Note

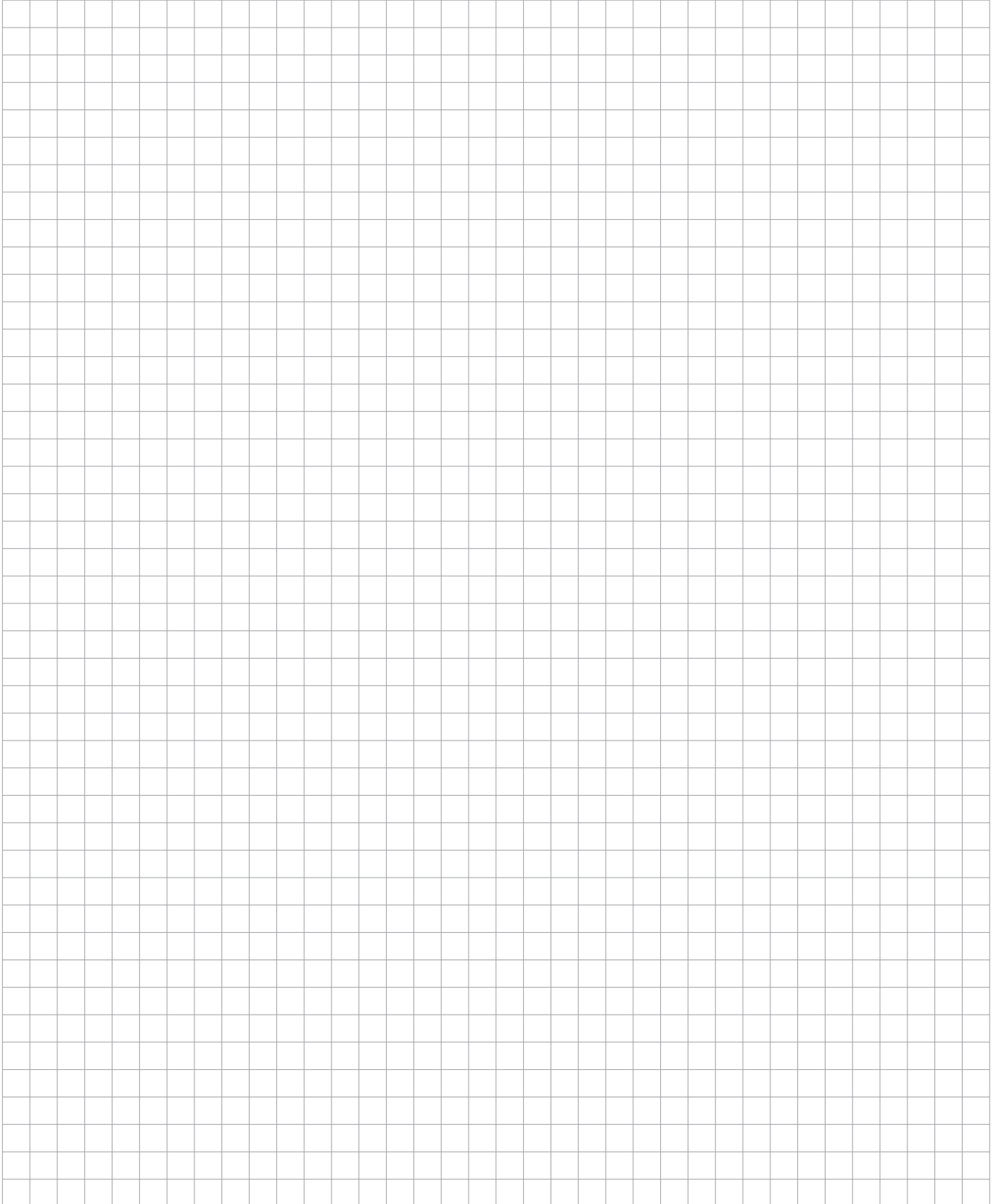

Note



Note

A large grid of graph paper, consisting of approximately 25 columns and 50 rows of small squares, intended for taking notes.

Product Portfolio

Transfer Pumps

Transfer pumps for lubricating oil supply equipment, low pressure filling and feed systems, dosing and mixing systems.

Mobile Hydraulics

Single and multistage high pressure gear pumps, hydraulic motors and valves for construction machinery, vehicle-mounted machines.

Flow Measurement

Gear and turbine flow meters and electronics for volume and flow metering technology in hydraulics, processing and laquering technology.

Industrial Hydraulics / Test Bench Construction

Cetop directional control and proportional valves, hydraulic cylinders, pressure, quantity and stop valves for pipe and slab construction, hydraulic accessories for industrial hydraulics (mobile and stationary use).

Technology Test benches / Fluid Test benches.



KF4...112/GB/08.10

KRACHT